

- 225mm THICK CL. C28/35 MASS CONCRETE FOUNDATIONS.
- NOTE NOT USED SEE NOTE 5 (ALL MANHOLE BENCHING CAST OFF SITE BY PRECAST CONCRETE SUPPLIER, OEA).
- NOTE: WHERE PIPE DIAMETER CHANGES AT A MANHOLE PIPE CROWNS TO LINE UP
- MANHOLE CONSTRUCTION:**
 - FOR SURFACE WATER MANHOLES HIGH-DENSITY BLOCKS TO CL. S10 (10N STRENGTH PINK COLOUR) OF I.S.20 PART 1:1987 OR CL. 30N/20mm INSTU CONCRETE.
 - BLOCK WORK SHALL BE BEDDED & JOINTED USING MORTAR TO I.S.406. BEDS & VERTICAL JOINTS SHALL BE COMPLETELY FILLED WITH MORTAR AS THE BLOCKS ARE LAD.
 - JOINTS SHALL BE FLUSH POINTED AS THE WORK PROCEEDS.
- RELIEVING ARCH FORMED BY 215 x 103 x 65 SOLID ENGINEERING BRICK CLASS 'A' OR 'B' RELIEVING ARCHES USED IN BRICK OR BLOCK WORK MANHOLES EXTEND OVER FULL THICKNESS OF WALL. A DOUBLE ARCH IS TO BE FORMED FOR PIPE DIAMETERS GREATER THAN 600mm.
- ALL MANHOLE BENCHING CAST OFF SITE BY PRECAST CONCRETE SUPPLIER, OEA.
- ANY UNUSED PRECAST CONNECTION POINTS ARE TO BE PLUGGED IN ACCORDANCE WITH THE SPECIALIST SUPPLIERS RECOMMENDATIONS.
- STANDARD RUNGS AT 300 C/C VERTICALLY & GALVANISED TO THE LATEST VERSION OF B.S. 729 OR EQUIVALENT. NOTE: STEP IRONS ARE NOT ACCEPTABLE.
- 600mm SQUARE PIPE IN ROOF SLAB. NOTE: FOR MANHOLES < 1.0m Dp. 90x675 CLEAR OPENING COR THE COVER & FRAME. FOR MANHOLES > 1.0m Dp. < 1.35m Dp. FORM 1200x675 CLEAR OPENING.
- R.C. ROOF SLAB SHALL BE 200mm THICK IN CLASS C25/30, WITH 40mm COVER TO A393 STEEL, DESIGNED TO BS 8100 TO TAKE FULL TRAFFIC LOADING.
- 1 TO 2 COURSES OF SOLID ENGINEERING BRICKS CL. 'A' TO I.S.91:1983 SET IN 1:3 (CEMENT & MORTAR)
- CLASS D400 OR E600 MANHOLE COVER & FRAME TO I.S./EN124. 150mm DEEP FRAME FOR ROADS & 100mm DEEP FOR FOOTPATHS & GREEN AREAS. NON-ROOF DESIGN. CLOSED KEYWAYS. MANUFACTURED FROM SPHERICAL GRAPHITE CAST IRON (DUCILE CAST IRON). 600 x 600 (600) CLEAR OPENING. COVER & FRAME COATED IN BITUMEN OR OTHER APPROVED MATERIAL. COVER TO HAVE A MINIMUM MASS OF 140kg/m². FRAME BEARING AREA SHALL BE 80,000mm² MIN. FRAMES SHALL BE DESIGNED TO PREVENT COVER FALLING INTO MANHOLE. FRAMES SHALL BE BEDDED ON APPROVED MORTAR TO MANUFACTURERS INSTRUCTIONS.
- 600mm LENGTH OF ROCKER PIPE & PIPE JOINT EXTERNAL TO MANHOLE TO BE NO FURTHER THAN 600mm FROM THE INNER FACE OF MANHOLE WALL.
- TOP HOLES OF 230mm MINIMUM DEPTH & GALVANISED STEEL SAFETY RAILINGS TO BE PROVIDED IN BENCHING OF SEWERS GREATER THAN 525mm & DEPTHS TO INVERT > 3m FOR ACCESS TO INVERT.
- A SAFETY CHAIN IS TO BE PROVIDED ON PIPES THAT EXCEED 450mm IN DIAMETER. MILD STEEL SAFETY CHAIN SHALL BE 10mm NOMINAL SIZE GRADE M(H) NON-CALIBRATED CHAIN, TYPE 1, COMPLYING WITH B.S.4942 PART 2 OR EQUIVALENT
- WHEN DEPTH OF MANHOLES TO INVERT IS GREATER THAN 3.0m LADDERS SHALL BE USED, INSTEAD OF RUNGS TO B.S.4211 OR EQUIVALENT EXCEPT THAT STRINGERS SHOULD BE NOT LESS THAN 65 x 12mm IN SECTION & RUNGS 25mm IN DIAMETER. FIXED LADDERS SHOULD MEET THE DIMENSIONAL REQUIREMENTS OF B.S.4211 OR EQUIVALENT. DISTANCE FROM THE TOP RING OF THE LADDER TO GROUND LEVEL SHOULD NOT EXCEED 500mm.
- LADDER STRINGERS SHOULD BE ADEQUATELY SUPPORTED FROM THE MANHOLE WALL AT INTERVALS OF NOT MORE THAN 2.0m. STRINGERS SHOULD BE BOLTED TO CLEATS TO FACILITATE RENEWAL.
- ALL LADDERS, RUNGS, H/RAILS, SAFETY CHAINS ETC. SHALL BE HOT DIP GALVANISED TO B.S.729 OR EQUIVALENT.
- PIPE SHOULD BE CUT FLUSH WITH THE INSIDE SURFACE OF THE MANHOLE WALL SO THAT THE CHANNEL EXTENDS THE FULL LENGTH OF THE MANHOLE (EXCEPT FOR PRECAST MANHOLES).
- FOR MANHOLES > 3m Dp. PROVIDE AN INTERMEDIATE ROOF SLAB WITH A 900x900 OR 910x910 SQUARE OPENING.
 - ALL MANHOLES SHALL BE WATER TIGHT TO THE SATISFACTION OF THE ENGINEER.
 - FORMWORK TO REINFORCED CONCRETE & MASS CONCRETE SHALL COMPLY WITH CLASS 2, SECTION 6.2.7, B.S.8110:PART 1:1997
 - FINISH TO THE TOP OF SLABS SHALL COMPLY WITH TYPE 'A', SECTION 6.2.7, B.S.8110:PART 1:1997
 - PLAN DIMENSIONS OF MANHOLES ARE BASED ON BLOCK WORK HAVING A CO-ORDINATING SIZE OF 450 x 225 x 100. FOR PIPE DIAMETER > 750mm USE MANHOLE WITH INTERNAL DIAMETER SIZE = PIPE SIZE + 1m + 300mm
 - MANHOLES ARE DESIGNED TO B.S.8005 & WALL THICKNESS TO I.S.325 BLOCK WORK DESIGN CODE TAKING GRANULAR FILL PRESSURE & H.B. SURCHARGE.
 - REINFORCEMENT TO SLABS TO ENGINEERS DETAILS.
- FOR MANHOLES > 3m DEPTH TO INVERT USE C25/30 INSTU CONCRETE. REINFORCING MESH REF. A393 TO BE FIXED AT MID POINT OF WALL. ADDITIONAL REINFORCEMENT TO BE SUPPLIED OVER PIPE CROWN.
- PRECAST MANHOLES. CHAMBER WALLS & COVER SLAB TO BE CONSTRUCTED TO I.S. EN 1917 & I.S.420:2004
- MANHOLE OPENINGS TO BE SITUATED FURTHEST FROM THE NEAREST CARRIAGEWAY. MANHOLE STEPS-ACCESS TO BE POSITIONED TO ALLOW VIEWING OF CONCERNING TRAFFIC
- FOR BEDDING & SEALING OF CHAMBER RINGS, THE TOP RING (TO PRECAST COVER SLAB) & BOTTOM RING TO BE BEDDED WITH CEMENT MORTAR. FOR INTERMEDIATE RINGS, JOINTS TO BE SEALED WITH APPROVED PRE-FORMED JOINTING STRIP.
- PRECAST MANHOLES TO BE SURROUNDED WITH A MINIMUM OF 150mm THICK GRADE C20/25 CONCRETE.
- CONCRETE SEWER PIPES WITH SPIGOT & SOCKET JOINTS & RUBBER RING FITTINGS TO COMPLY WITH IS/EN 1916 & IS 6 2004 OR EQUIVALENT STAIRD CLASS M OR CLASS H.
- VITRIFIED CLAY PIPES & FITTINGS COMPLYING WITH THE REQUIREMENTS OF IS/EN 295-1/2/3: 1992 OR EQUIVALENT STAIRD CLASS 160 OR CLASS 200.
- UNPLASTICIZED POLYVINYLCHLORIDE (UPVC) PIPES & FITTINGS IN ACCORDANCE WITH THE REQUIREMENTS OF IS 424.
- CONCRETE BED & SURROUND TO BE A MINIMUM 150mm THICK IN-SITU CONCRETE CLASS 20N/20mm & HAUNCHED HALF WAY UP THE BARREL OF THE PIPE.
- GRANULAR BED & SURROUND FOR RIGID PIPES TO BE EITHER:
 - 14mm TO 5mm GRADED AGGREGATE OR
 - 10mm SINGLE SIZED AGGREGATE.
- ALL COMPLYING WITH THE REQUIREMENTS OF IS 5: PART 1: 1990, TABLE 7 & SHOULD HAVE A COMPACTION FACTOR VALUE NOT GREATER THAN 0.2 WHEN MEASURED IN ACCORDANCE WITH BS 8301: 1985, APPENDIX D.
 - 14mm TO 5mm GRADED AGGREGATE (PIPE DIAMETER < 315mm)
 - 10mm SINGLE SIZED AGGREGATE (PIPE DIAMETER < 315mm)
- ALL COMPLYING WITH THE REQUIREMENTS OF IS 5: PART 1: 1990, TABLE 7 & SHOULD HAVE A COMPACTION FACTOR VALUE NOT GREATER THAN 0.2 WHEN MEASURED IN ACCORDANCE WITH BS 8301: 1985, APPENDIX D. GRANULAR SLAB FILL & COVER TO BE PLACED UNIFORMLY ON EITHER SIDE OF THE PIPE IN LAYERS NOT EXCEEDING 100mm, EACH LAYER BEING COMPACTED BY H&B TAMPING UNTIL THE PIPE HAS A MINIMUM 150mm COMPACTED COVER.
- GRANULAR BACKFILL MATERIAL SHALL BE IN COMPLIANCE WITH CLAUSE 804 (GRANULAR MATERIAL, TYPE B) OF THE NRA SPECIFICATION FOR ROAD WORKS. GRANULAR BACKFILL SHOULD BE PLACED UNIFORMLY ON EITHER SIDE OF THE PIPE IN LAYERS NOT EXCEEDING 100mm, EACH LAYER BEING COMPACTED BY HAND & TAMPING UNTIL THE PIPE HAS MINIMUM OF 300mm COMPACTED COVER. CARE SHOULD BE TAKEN THAT THE PROCESS OF COMPACTION DOES NOT DISPLACE THE PIPE FROM ITS CORRECT LINE & LEVEL. SUBSEQUENT LAYERS OF GRANULAR FILL TO BE WELL COMPACTED IN 150mm THICK LAYERS TO THE LOCAL AUTHORITY ROAD DIVISION SPECIFICATION. MECHANICAL COMPACTION EQUIPMENT SHOULD NOT BE USED UNTIL THERE IS A MINIMUM OF 450mm COMPACTED COVER OVER THE CROWN OF THE PIPE.
- SELECTED FILL SHOULD BE FREE FROM STONES LARGER THAN 37mm, LUMPS OF CLAY OVER 75mm, TWIGS, FROZEN MATERIAL & VEGETABLE OR FOREIGN MATTER. SELECTED FILL SHOULD BE PLACED UNIFORMLY ON EITHER SIDE OF THE PIPE IN LAYERS NOT EXCEEDING 100mm, EACH LAYER BEING COMPACTED BY H&B TAMPING UNTIL THE PIPE HAS A MINIMUM OF 150mm COMPACTED COVER. CARE SHOULD BE TAKEN THAT THE PROCESS OF COMPACTION DOES NOT DISPLACE THE PIPE FROM ITS CORRECT LINE & LEVEL. SUBSEQUENT LAYERS OF GRANULAR FILL TO BE WELL COMPACTED IN 150mm THICK LAYERS.
- GENERAL BACKFILL MATERIAL SUITABLE FOR BACKFILL ABOVE SELECTED FILL MATERIAL SHOULD BE FREE FROM BOULDERS, LUMPS OF CONCRETE, TWIGS & VEGETABLE OR FOREIGN / CONTAMINATED MATTER. GENERAL BACKFILL SHOULD BE PLACED IN LAYERS NOT EXCEEDING 300mm, EACH LAYER BEING WELL COMPACTED. MECHANICAL COMPACTION EQUIPMENT SHOULD NOT BE USED UNTIL THERE IS A MINIMUM OF 450mm COMPACTED COVER OVER THE CROWN OF THE PIPE.
- PIPES WITH INADEQUATE COVER TO BE FULLY SURROUNDED IN 150mm THICK GRADE C20/25 CONCRETE.
- LEAN-MIX BACKFILL TO TRENCHES IN EXISTING ROAD, WHERE REQUIRED BY THE LOCAL AUTHORITY TO BE GRADE C20/25 CONCRETE.
- SURFACING TO BE IN ACCORDANCE WITH THE ROAD SPECIFICATION & IF APPROPRIATE, LOCAL AUTHORITY REQUIREMENTS.
- GOOD QUALITY TOPSOIL, 450mm MINIMUM THICK, TO BE PLACED OVER BACKFILL IN ACCORDANCE WITH PARKS DEPARTMENT / LANDSCAPE ARCHITECTS REQUIREMENTS.
- A/s (ARMSTRONGS JOINTIONS)
 - TO BE USED FOR PIPE DEPTHS UP TO 600mm
 - INTERNAL A/s IF REQUIRED TO HAVE DOUBLE SEALED COVERS
 - EXTERNAL A/s TYPICALLY TO BE PROPRIETARY UPVC WITH 35KN COVER
 - EXTERNAL A/s IN AREAS SUBJECT TO TRAFFIC TO BE SURROUNDED 150 WITH C20 CONCRETE & TO HAVE A CLASS D COVER & FRAME SUPPORTED OFF THE CONCRETE SURROUND OR ALTERNATIVELY USE 450A PRECAST RINGS WITH A COVER SLAB AS PER NOTE 21.
- BRANCH PIPES INTO MANHOLES: BENCHING TO BE SHAPED SO AS TO GUIDE THE FLOW IN THE FLOW DIRECTION. THE LENGTH OF THE MANHOLE BASED ON THE SIDE WITH THE GREATEST NUMBER OF BRANCHES EQUAL TO 300mm PLUS THE SUM OF THE BRANCH DIAMETERS PLUS 200mm PER BRANCH FOR BRANCHES UP TO 150mm (OR 300mm FOR BRANCHES GREATER THAN 150mm DIAMETER).

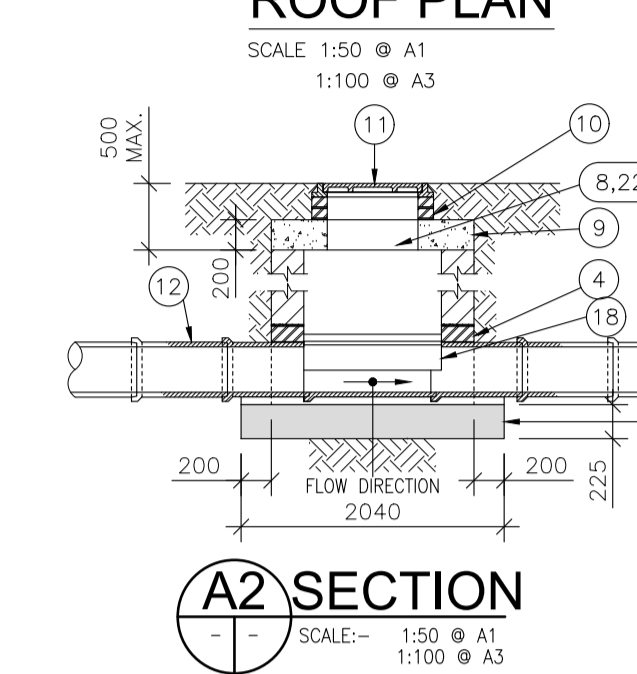

MANHOLE TYPE A (BLOCKWORK)
DEPTH TO INVERT < 1m
FOR PIPE DIAMETERS 150-450mmØ

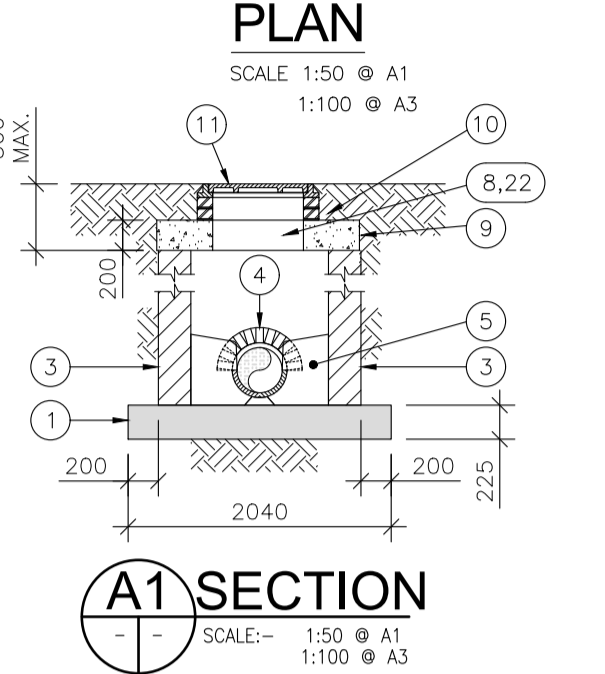
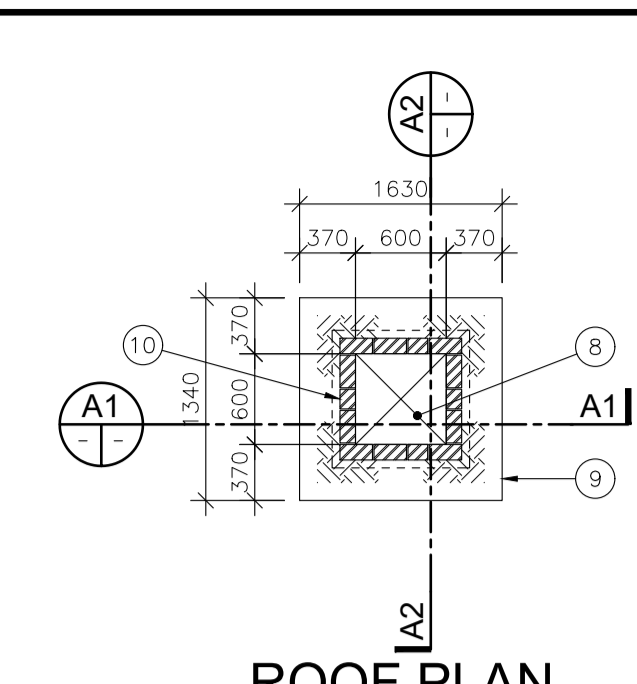
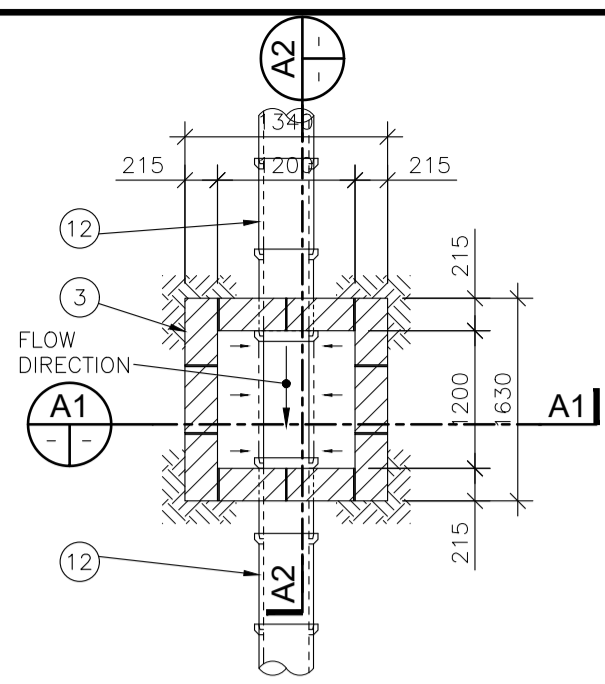
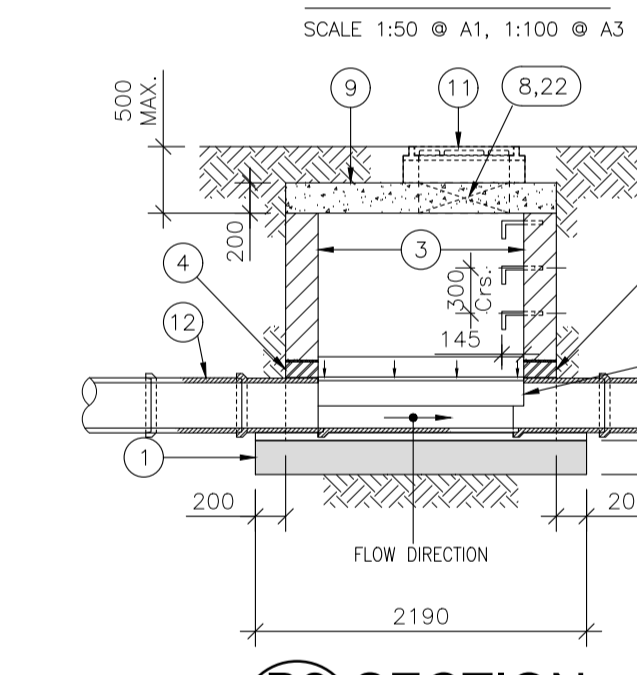
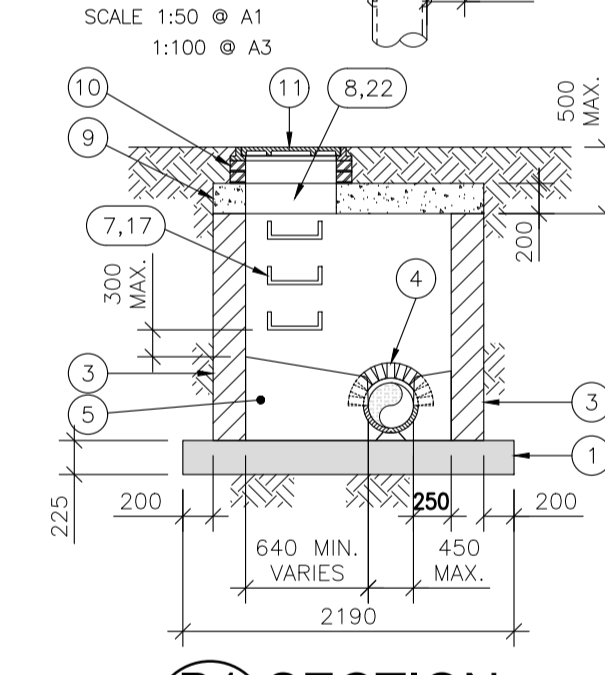
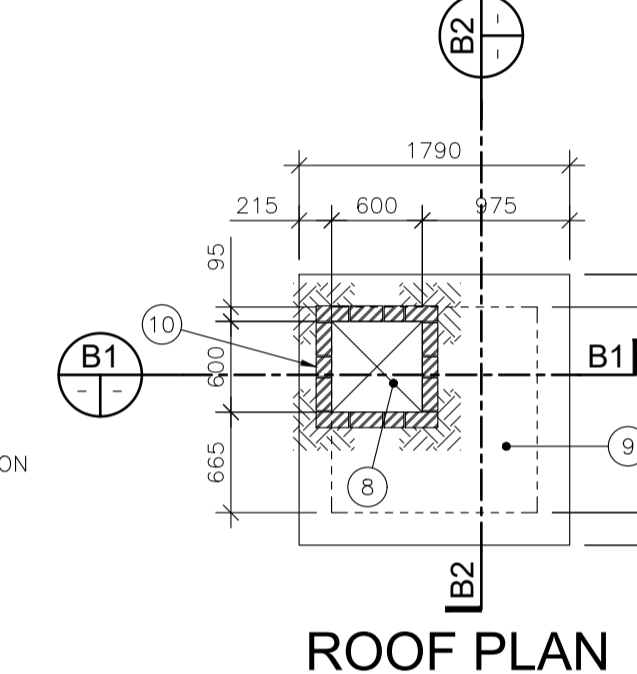
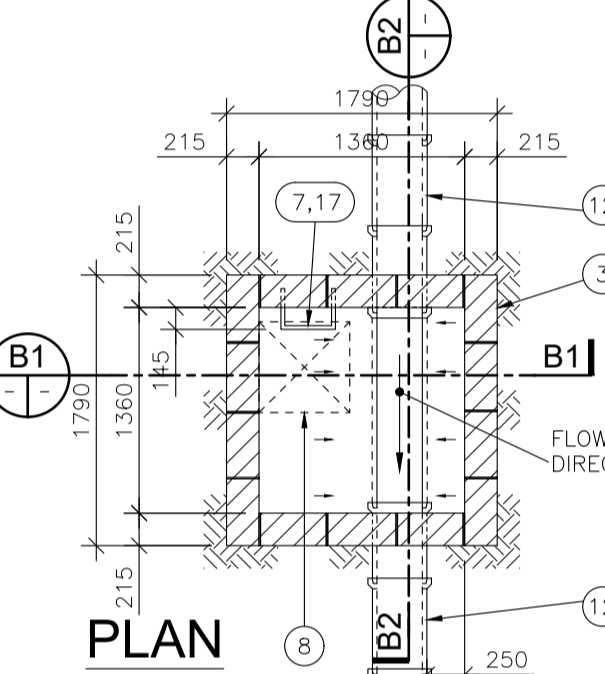

MANHOLE TYPE B (BLOCKWORK)
1m ≤ DEPTH TO INVERT < 3m
FOR PIPE DIAMETERS 150-450mmØ

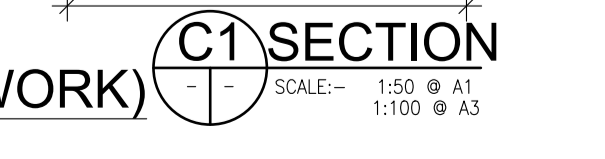
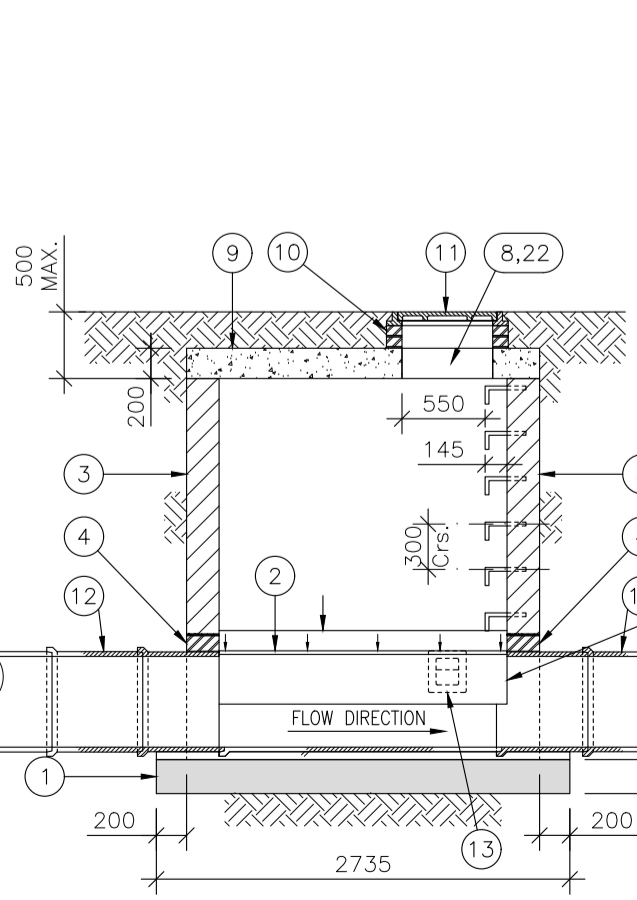
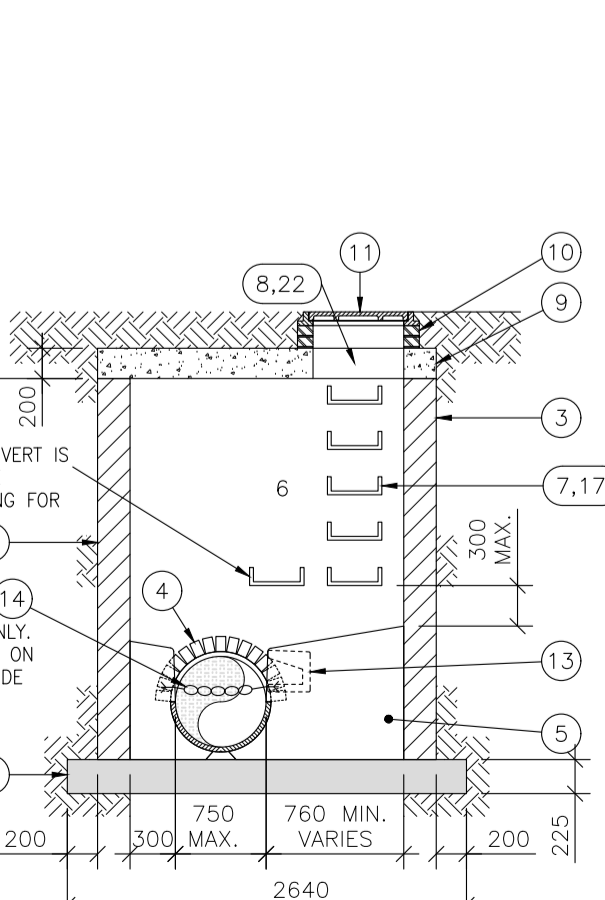

MANHOLE TYPE C (BLOCKWORK)
1m ≤ DEPTH TO INVERT < 3m
FOR PIPE DIAMETERS 525-750mmØ

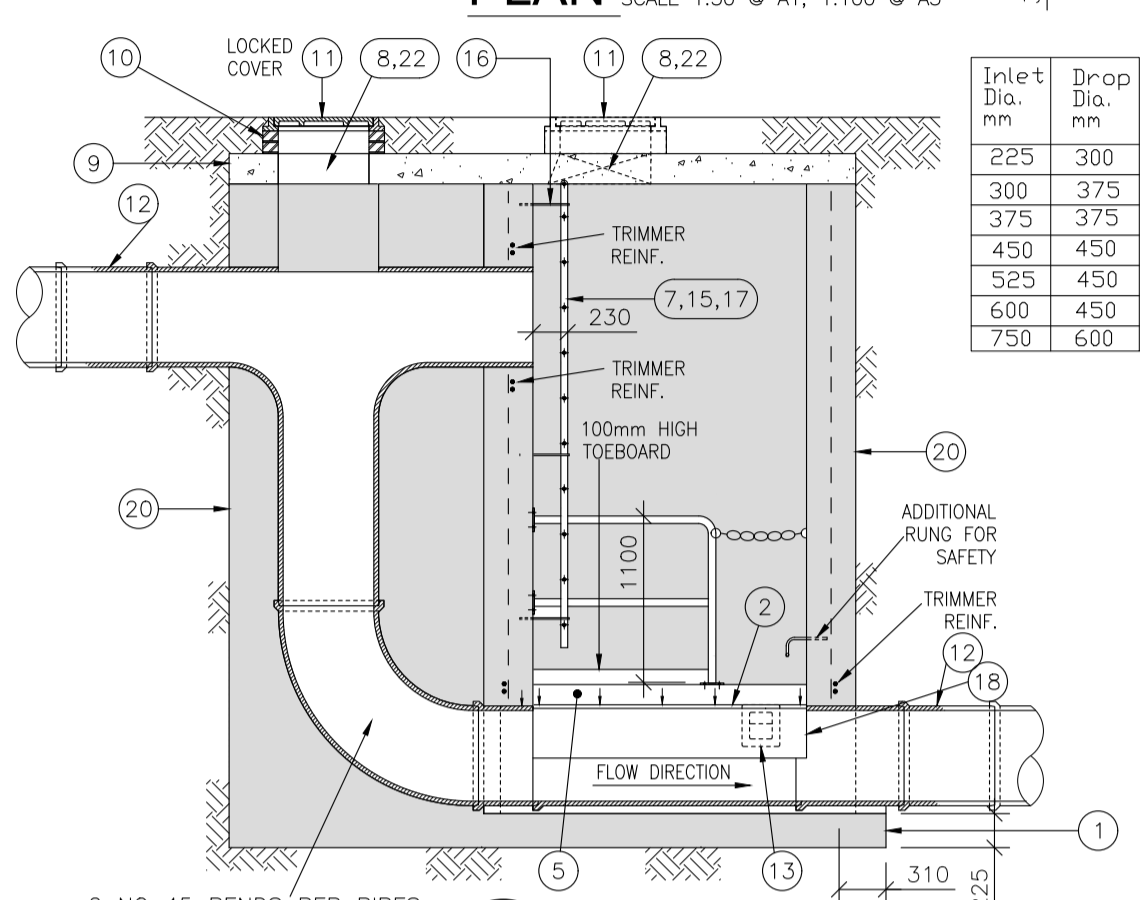
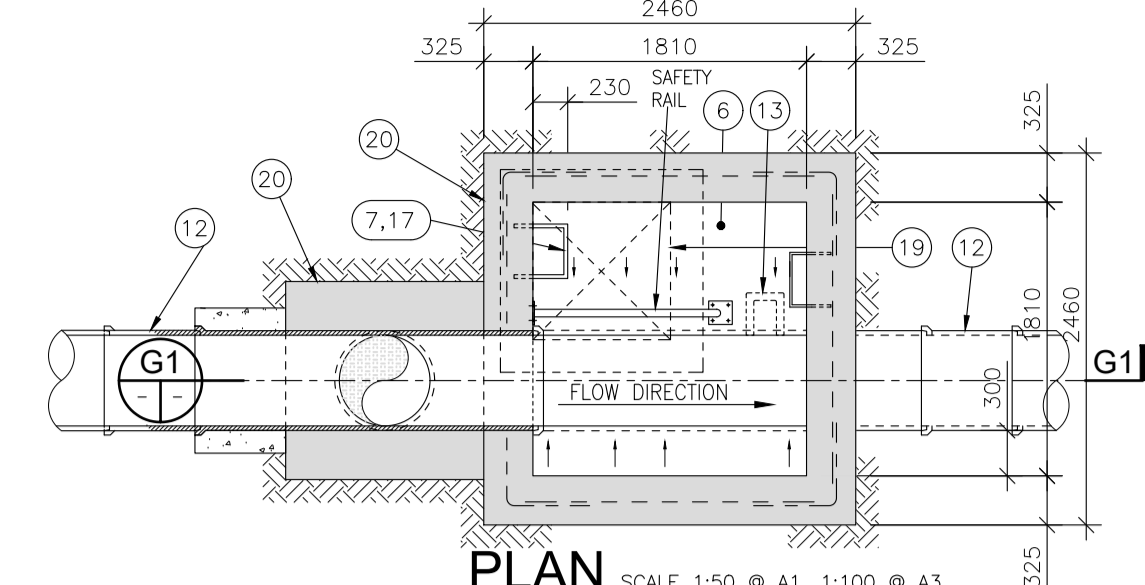

MANHOLE TYPE G BACKDROP MANHOLE
FOR ALL PIPE DIAMETERS
DROP > 600 FOR 225 & 300 PIPE DIAMETERS
DROP > 750 FOR GREATER PIPE DIAMETERS

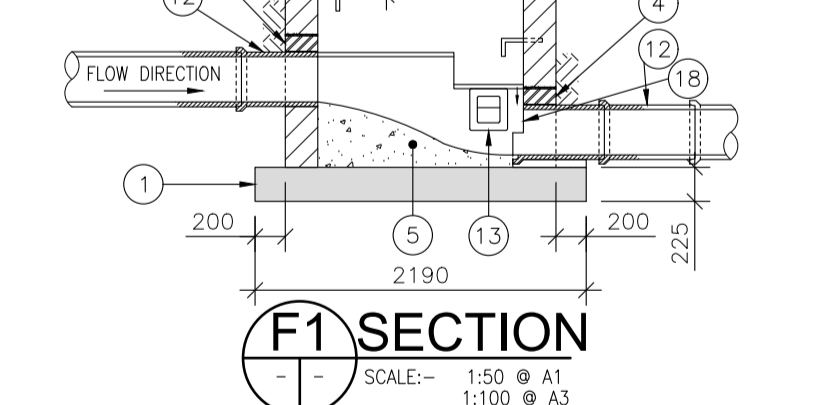
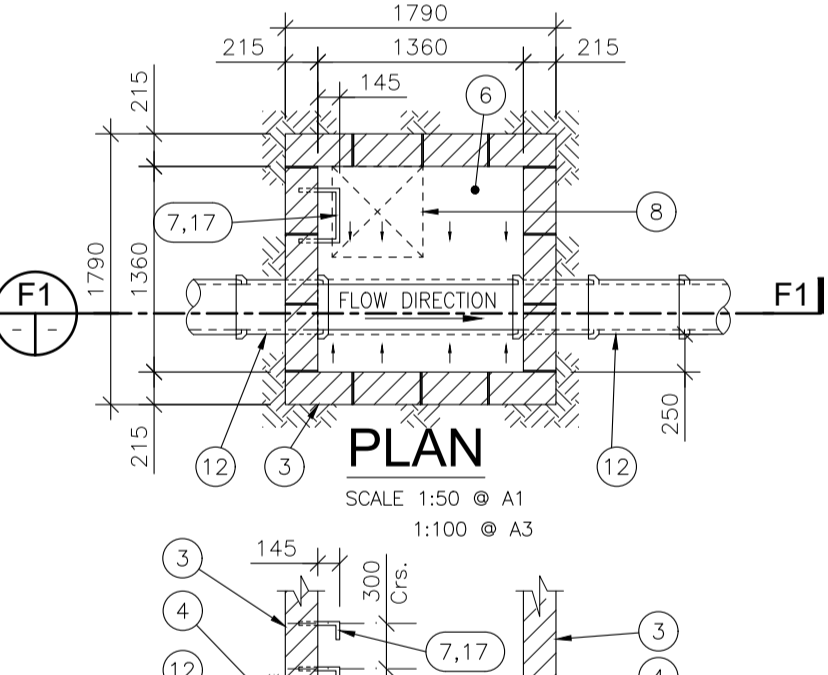
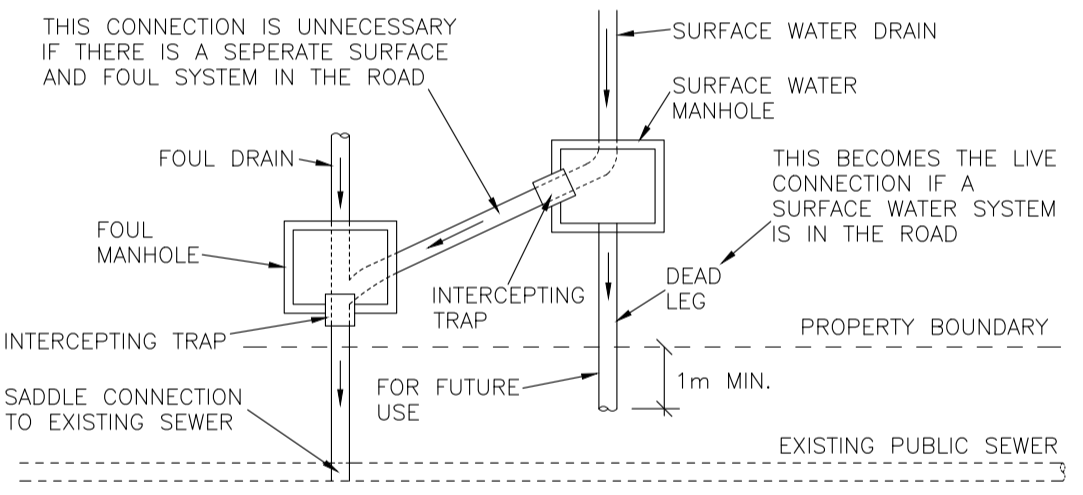

TABLE F

INLET Ø	DEPTH (max)
A	H
225	600
300	600
375	750
450	750
525	750
600	750
750	750

WHEN THE DROP 'H' IS GREATER THAN THE MAX. VALUE SHOWN USE BACKDROP MANHOLE

MANHOLE TYPE F RAMP MANHOLE



PLAN OF SEPARATE CONNECTION TO COMBINED SEWER N.T.S.

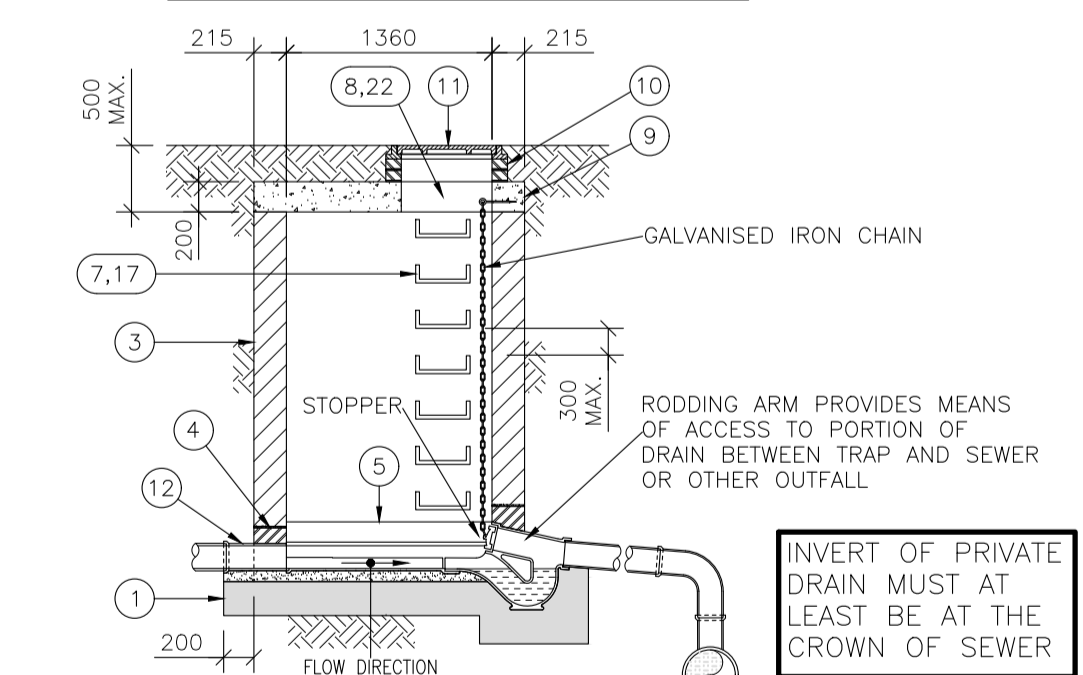

MANHOLE TYPE H INTERCEPTOR TRAP DETAILS
FOR OUTFALL MANHOLES AT SITE BOUNDARY PRIOR TO CONNECTING TO PUBLIC SYSTEM

- NOTE:
- BEFORE DRAINAGE WORKS ARE COMMENCED THE CONTRACTOR IS TO ESTABLISH IF DRAINAGE WORKS ARE TO BE TAKEN IN CHARGE BY THE LOCAL AUTHORITY. IF THIS IS THE CASE THE CONTRACTOR IS TO GET APPROVAL FROM THE LOCAL AUTHORITY FOR DETAILS SHOWN ON THIS DRAWING BEFORE COMMENCING THE WORK.
 - ALL MANHOLE BENCHING CAST OFF SITE BY PRECAST CONCRETE SUPPLIER, OEA.
 - ANY UNUSED PRECAST CONNECTION POINTS ARE TO BE PLUGGED IN ACCORDANCE WITH THE SPECIALIST SUPPLIERS RECOMMENDATIONS.

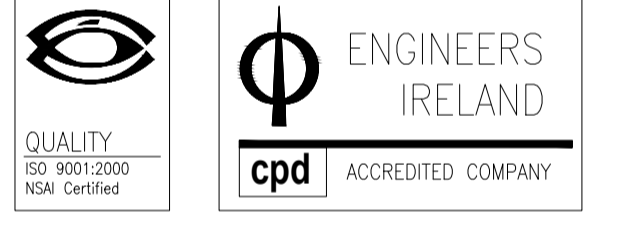

Rev.	Date	Description	Des.	Chkd.	Apprv.
PL1	20.04.18	PLANNING ISSUE	EM	NP	NP

Client: **WATERFORD CITY AND COUNTY COUNCIL**

Job Description: **SOCIAL HOUSING PPP BUNDLE 2 SUIVEKEALE, WATERFORD CITY**

Sheet: **PLANNING**

Drawing Title: **EXTERNAL DETAILS SHEET 1 STORM WATER MANHOLE DETAILS**

Project No: **17K007-SHB2** Drawing Ref: **SLI-C-050** Rev: **PL1**

Date: **07.11.16** Scale: **AS SHOWN**

Drawn By: **P.FUNCHEON** Checked By: **P.FUNCHEON** Approved By: **N.PATTERSON**

