



**Comhairle Cathrach
& Contae Phort Láirge**
Waterford City
& County Council

Waterford City and County Council

Public Lighting Specification

**First Issue
March 2020**

Adhering to this specification does not ensure compliance with relevant international and national standards, best practise guidance, or with safety and health legislation. Clients, designers, and contractors should make themselves aware of their own statutory duties under Irish safety and health legislation.

Compliance with this specification does not ensure design approval by Waterford City and County Council.

This specification supersedes previous specifications used within the city and county. It is the intention of Waterford City and County Council to review and update this specification regularly.



Contents

Document Control	ii
Table of Figures	ii
Introduction	1
Objectives	1
1 General Requirements.....	1
1.1 Appropriate Lighting Design	2
2 Safety and Health	3
3 Client and Designer Duties.....	3
4 Works to Partial Circuits	4
5 Lighting Design for New Projects.....	5
6 Lighting Design for Upgrade Projects	7
7 Lighting Carparks	8
8 Dimming	8
8.1 Dimming Luminance Lighting	9
8.2 Dimming Illuminance Lighting	9
8.3 Dimming Lighting in Amenity Areas.....	10
8.4 Dimming Lighting in Surface Carparks	10
9 Light Source Temperature CCT	10
10 Design Approval.....	10
11 Electrical Connection.....	12
12 Protection of Flora and Fauna	12
Conclusion	13
References.....	14
Appendix A Cable and Ducting Specification	16
Appendix B Cable Access Chamber Specification	18
Appendix C Column and Bracket Specification	19
Appendix D Supply Cabinet Specification	21
Appendix E Column Installation	24
Appendix F Electrical Design	27
Appendix G LED Luminaire Specification	29
Appendix H Taking in Charge.....	32
Addendum 1 Designer Checklist.....	33



Addendum 2	Duct Detail.....	34
Addendum 3	Cable Access Chamber Detail	35
Addendum 4	Column Root Protection Detail	36
Addendum 5	Door Height Detail.....	37
Addendum 6	Column Orientation Detail.....	38
Addendum 7	6m & 8m Column Foundation Detail	39
Addendum 8	10 and all Traffic Route Column Foundation Detail	40

Document Control

Issue Date	Prepared By	Approved By
10 th March 2020	Patrick Redmond	Liam Fleming

Table of Figures

Figure 1: Dimming Profiles.....	9
Figure 2: Road crossing duct detail	16
Figure 3: Cable access chamber	18
Figure 4: Cable slot detail.....	19
Figure 5: Pillar spacing.....	21
Figure 6: Midi pillar electrical schematic	22
Figure 7: Door positioning	24
Figure 8: Column door height.....	25
Figure 9: Column Electrical Schematic	26

*Waterford City and County Council would like to thank
Redmond Analytical Management Services Ltd.
for their technical assistance in preparing this specification.*



Introduction

Waterford City and County Council intend to ensure that all projects with a public lighting element will provide a sustainable, energy efficient lighting solution. This document refers to international and national standards, along with codes of practise, and best practise documents that designers must comply with in order to meet our required standards.

Whilst this document does not intend to specify lighting equipment, it does intend to stipulate a minimum performance standard for all the equipment utilised within public lighting installations.

This document does not specify a specific lighting category with which designers should comply, rather designers should select appropriate lighting levels from the pertinent standard with which to light their projects and confirm this selection with Waterford City and County Council prior to undertaking the design. This latitude is to enable the competent lighting designer scope to produce appropriate, compliant, and energy efficient lighting solutions.

Objectives

Public lighting is an important addition to the built environment. Lighting gives a sense of safety and security to our residential areas and vibrancy to our commercial centres. Public lighting makes navigating about our community easier through the hours of darkness, improves traffic flow and raises general safety.

Public lighting infrastructure in the city and county places a considerable burden on the local authority's resources and therefore it is in everyone's interests that this infrastructure is as energy efficient and maintenance friendly as possible.

Waterford City and County Council's *Public Lighting Specification* lays down how the lighting task should be approached for all applications within the city and county regardless of whether the lighting is to be taken in charge or not.

This public lighting specification supersedes all previous public lighting specifications published by Waterford City and County Council. The guidance offered for public lighting layouts within *Recommendations for Site Development Works for Housing Areas* is no longer acceptable.

1 General Requirements

Waterford City and County Council, Roads Department, situated at City Hall, The Mall, Waterford, is the official lighting authority for transport infrastructure, housing, industrial and commercial developments in county Waterford.

All lighting schemes for transport infrastructure, housing, industrial or commercial developments carried out by developers or their contractors in county Waterford shall comply with the requirements of, and be approved by, Roads Department, Waterford City and County Council, irrespective of whether the lighting is to be taken in charge or not.

This specification sets down appropriate standards and technical specifications which shall be complied with by anyone undertaking public and private developments or, undertaking upgrades to the existing network.

The approach to the design process shall be the same regardless of the project being a new build or an upgrade of the existing lighting infrastructure.



All exterior lighting shall comply to the Irish Standard for public lighting *I.S. EN 13201-2:2015* (CEN/CENELEC, 2016) while observing the latest *ETCI* regulations and *ESB Networks* distribution system interface requirements.

Lighting designs for major traffic routes and junctions shall follow the guidance provided within *DN-LHT-03038 Design of Road Lighting for the National Road Network* along with the associated *Transport Infrastructure Ireland* design manuals.

In addition, designers should observe the general guidance offered in *BS 5489-1:2013 Code of Practise for the Design of Road Lighting Part 1: Lighting of Roads and Public Amenity Areas* (British Standards Institute, 2012). Particularly regarding photopic scotopic correction, locating columns and the calculation of maintenance factors.

Where special circumstances occur that require deviation from this document, these deviations shall be clearly agreed in writing with Waterford City and County Council in advance of any work commencing on site and as such, must be adhered to for any public lighting installation to be taken in charge by Waterford City and County Council.

LED luminaires shall only be considered for public lighting applications. Luminaires shall be capable of CMS control by replacing the PECU with a communications node.

Traffic lights and lighting associated with pedestrian crossings shall have a separate *MPRN* number to public lighting.

Lighting designers shall approach the design task in a holistic manner, sympathetic to the nature and location of the project. Consideration shall be given to the people who will use and live with the lighting installation. Care will be taken, as far as practicable, by the lighting designer to ensure that the impact on flora and fauna will be minimised.

Specifications and requirements for the various individual components that make up a general lighting infrastructure is laid out in *appendages A through G*. Any detail of an individual lighting design not covered should be brought to the attention of Waterford City and County Council for clarification.

1.1 Appropriate Lighting Design

Adherence to Waterford City and County Council's public lighting specification, or approval of the lighting design by Waterford City and County Council does not imply compliance with any standard, or that the lighting infrastructure is fit for purpose. It will be the duty of the developer to investigate and remedy any issues identified by Waterford City and County Council or its agents during any phase of design approval, construction, inspection, or commissioning. Lighting infrastructure shall only be approved, or taken in charge, upon any required remedial work being completed.

Lighting designers shall be aware of their duty to provide appropriate, sustainable, energy efficient lighting solutions in line with the relevant international and national standards, statutory instruments, codes of practise and the codes of conduct of the professional bodies of which they are members.

The developer and contractor shall ensure that the lighting design approved by Waterford City and County Council be installed as per the approved design. Any changes to the approved lighting design shall be undertaken by the lighting designer and submitted to Waterford City and County Council for approval.

It is the intention of Waterford City and County Council that all lighting installed within the region be appropriate to the local environment, the task for which illuminance is provided,



be energy efficient and sustainable. The lighting infrastructure shall not impact negatively on the local landscape, residents, visitors, or the flora and fauna.

The developer shall provide the lighting designer with any environmental impact assessment, wildlife survey and any other information relevant to allow the lighting designer to provide appropriate measures to mitigate against damage or nuisance caused by light trespass in an appropriate manner.

The lighting design shall not place luminaires in line with, or directly above windows or the doors of residences.

2 Safety and Health

- 2.1 The developer shall comply with all the duties laid down in the *Safety, Health and Welfare at Work (General Applications) Regulations 2007* (Department of Enterprise, Trade and Employment, 2007).
- 2.2 The developer shall comply with all the duties laid down in the *Safety, Health and Welfare at Work (Construction) Regulations 2013* (Department of Jobs, Enterprise and Innovation, 2013)
- 2.3 All persons employed on the installation of public lighting must have received appropriate safety and health training in accordance with the *Safety, Health and Welfare at Work Act 2007* (Department of Enterprise, Trade and Employment, 2007) and *The Safety Health and Welfare at Work (Construction) Regulations 2013* (Department of Jobs, Enterprise and Innovation, 2013) and training in roadside working in accordance with Part 13 of the *Safety, Health & Welfare at Work (Construction) Regulations 2013* (Department of Jobs, Enterprise and Innovation, 2013) as amended, the *Code of Practice for avoiding Danger from Overhead Electricity Lines* (ESB Networks, 2019), and the *Code of Practise For Avoiding Danger From Underground Services* (Health and Safety Authority, 2016)
- 2.4 Any person who carries out specific works on public lighting in proximity to ESB networks is to hold an appropriate public lighting *Safety Approval Certificate* confirming that he is trained and competent to carry out such works.
- 2.5 Account shall be taken of any traffic management measures that may be required during the installation of public lighting schemes. This includes the requirement that a traffic management plan be designed by a holder of a current valid *Traffic Management Designer CSCS card* and implemented on site by a current valid *CSCS Signing, Lighting and Guarding on roads license holder*.

3 Client and Designer Duties

- 3.1 Developers and/or their agents shall ensure they comply with their statutory duties defined in the *Safety, Health and Welfare at Work (Construction) Regulations 2013*, particularly those duties detailed in *Part 2, Section 7 (2) and (5)* (Department of Jobs, Enterprise and Innovation, 2013).
- 3.2 Designers submitting lighting designs shall ensure they comply with their statutory duties defined in the *Safety, Health and Welfare at Work (Construction) Regulations 2013*, particularly those duties detailed in *Part 2, Section 15* (Department of Jobs, Enterprise and Innovation, 2013).



- 3.3 The *Safety, Health and Welfare at Work (Construction) Regulations 2013* clearly states that the *client (developer)* has a statutory duty to appoint a '*competent designer*' to undertake all design work. This statutory duty applies to lighting and associated electrical infrastructure design. The appointed '*competent designer*' must comply with their statutory duties which are clearly defined in *S.I. 291*. These statutory duties also apply to designs that are offered on an advisory basis and regardless to the contractual arrangements between the designer and the developer or client.
- 3.4 Designers must prepare, record and store written documentation clearly showing how design decisions are arrived at. Under *S.I. 291* the designer must share (if requested) such records with others that have an interest in the project. Waterford City and County Council clearly has an interest in all designs carried out for installation in its locale and may request such records from designers.
- 3.5 Waterford City and County Council reserve the right to have lighting designers demonstrate their competence to undertake lighting and associated electrical infrastructure designs, before approving that specific design.
- 3.6 Developers and their agents should be aware that 'designs' offered on an 'advisory basis' or on a *pro bono* basis still have to comply with the statutory duties defined in the *Safety, Health and Welfare at Work (Construction) Regulations 2013* (Department of Jobs, Enterprise and Innovation, 2013).

4 Works to Partial Circuits

- 4.1 All works to partial circuits will be subject to the full testing and certifying requirements of the *National Rules for Electrical Installations* (Electro-Technical Council of Ireland, 2016).

Attention shall be given to the requirements of *Annex 63B paragraph 1*. "Should the installer become aware of any defect in any part of the installation that would impair the safety of the new work, the client must be informed in writing thereof. No new work should commence until these defects have been made good." (Electro-Technical Council of Ireland, 2016)
- 4.2 Where existing hardware (columns, supply cabinets, etc.) are to be relocated/reused or in any way retained, the contractor must certify that all retained hardware is structurally sound and without damage to the protective coatings.
- 4.3 All due care must be taken in the protection of existing hardware. Any damage to existing equipment (both electrical and structural) must be reported to the local authority and it is the contractor's responsibility to supply and replace any damaged equipment in the course of their works.
- 4.4 Prior to the disconnection of any existing public lighting installations, a full *Risk Assessment* shall be undertaken regarding the impact of the interruption of the street lighting provision on all users - pedestrian, cyclist and vehicular. If deemed necessary, temporary lighting shall be provided.
- 4.5 Where the interruption of the street lighting provision cannot be avoided by the phased scheduling of works, written agreement must be sought from Waterford City and County Council for permission to temporarily power down and re-energise sections of the circuits on a phased basis.
- 4.6 If granted, the permission referenced above in no way absolves the contractor from his previously stated responsibilities regarding the inspection and testing of the



renewed circuits.

- 4.7 All electrical installation work is to be carried out by a contractor registered with *RECI* or *ECSSA*.
- 4.8 All waste is to be disposed of in accordance with the *WEEE Directive*.

5 Lighting Design for New Projects

- 5.1 Lighting designers shall refer to Waterford City and County Council's *Public Lighting Specifications* and ensure they comply fully with all requirements.
- 5.2 Lighting designs shall comply with Waterford City and County Council's *Public Lighting Specifications* even if there is no intention for the lighting infrastructure to be taken in charge by Waterford City and County Council.
- 5.3 Lighting designers shall select an appropriate lighting classification using the selection process detailed in *S.R. CEN/TR 13201-1:2014* (CEN/CENELEC, 2015). The lighting designer should then liaise with Waterford City and County Council to confirm the lighting classification.
- 5.4 Overall uniformity (U_o) has a significant impact on the visual quality of a lighting installation, and a high U_o value has a positive effect on user safety. Therefore, where a lighting classification does not state a value for U_o , the minimum value for U_o shall be taken to be 20%.
- 5.5 When designing to *P* classifications, the lighting designer shall apply a product specific scotopic photopic adjustment to the calculation, in line with the guidance offered in *A.3.3.3* of *BS 5489-1:2013* (British Standards Institute, 2012).

The minimum permitted lighting level with residential developments shall not be less than *I.S. EN 13201-2:2015 P4* at full output.

When designing to a *P4* classification, the minimum illuminance level shall not fall below 1_{LUX} , including the scotopic photopic adjustment. At minimum, an overall uniformity of 20% shall be achieved.

Dimming by 25% from 00:00 to 06:00 shall be applied to all residential lighting projects. However, should the designer's risk assessment find that dimming is not appropriate, this shall be agreed in writing with Waterford City and County Council.

Overall uniformity (U_o) shall not fall below 20% unless in exceptional circumstances and only with the agreement of the local authority.

- 5.6 Lighting calculations shall be undertaken in accordance with *I.S. EN 13201-3: 2015 Calculation of Performance* (CEN/CENELEC, 2015).
- 5.7 Lighting designers shall select an appropriate luminaire based on the luminaire specification in Appendix G and on an energy consumption assessment in accordance with the requirements of *I.S. EN 13201-5:2015 Energy Performance Indicators* (CEN/CENELEC, 2015).

Waterford City and County Council will reject luminaires or designs that they believe to be inefficient energy consumers.

- 5.8 Lighting designers shall refer to the following Regulations, Standards, and Guidance Documents:



S.I No. 291 of 2013: Safety, Health and Welfare at Work (Construction) Regulations 2013.

National Rules for Electrical Installations ET 101: 2008 Fourth Edition or later.

I.S. EN 13201:2015 Road Lighting, the suite of documents as appropriate.

BS 5489-1:2013 Code of Practice for the Design of Road Lighting. Part 1: Lighting of Roads and Public Amenity Areas.

Housing Schemes: Guidebook for ESB Networks Standards for Electrical Services (Revision 5).

Relevant guidance documents available from the *Institution of Lighting Professionals* as appropriate.

Relevant guidance documents available from the *Society of Light and Lighting* as appropriate.

- 5.9 Lighting designers shall approach the design process in a holistic manner, taking account of lighting levels in the general area and at the access points to the project/development. Maintenance access and longevity of installation shall be central to the design.
- 5.10 Lighting designers shall pay attention to the *General Principles of Prevention* (Department of Jobs, Enterprise and Innovation, 2013) both for construction and for future maintenance.
- 5.11 Careful consideration shall be given to future maintenance requirements. Particularly access for maintenance crews to the lighting equipment, including safe ingress and egress to the equipment location.
- Where access by *MEWP* is difficult, or which would require the lengthy reversing of vehicles, then raise and lowering columns shall be used.
- 5.12 The design should represent the planned construction phases and should be self-contained within each construction phase.
- 5.13 No component of the lighting infrastructure shall stand on, or pass under, private property.
- 5.14 Consideration shall be given to the protection of persons from striking columns, both in motorised vehicles and cycles. Column set back guidance offered in 4.3.3.3 of *BS5489-1:2013* (British Standards Institute, 2012) shall be observed.

Public lighting columns represent a potential hazard to cyclists, vehicle drivers and their passengers. When shared surfaces are used, such as in *Homezones* and car parks, a suitable method of protection from the risk of public lighting column strikes shall be offered that does not conflict with the ethos of shared surface design principles. Barriers, bollards or other such structures are not acceptable protection methods. The project architect shall ensure therefore, that sufficient space is allocated within the development to allow for sufficient column setbacks.

Where appropriate setbacks cannot be achieved, or appropriate remedial measures cannot be taken, then passively safe columns and associated electrical disconnects shall be used in accordance with *I.S. EN 12767:2007*.



- 5.15 The effects of planned and existing trees and tall shrubs shall be considered during the design process to ensure that they do not block light and cause excessive shadowing. A minimum clearance from the widest part of the mature tree canopy equal to the column height, shall be used to ensure light distribution is not inhibited.

In new developments, the economic and appropriate locating of columns shall take priority over planned tree planting. Whilst the local authority recognises the importance of trees and planting within the streetscape, it shall not be to the detriment of appropriate lighting levels, or to the efficacy of the lighting infrastructure.

- 5.16 The temperature at which the luminaire photometry was measured, or derived, shall be stated on the design calculation cover. Photometry measured below 15°C is not acceptable.

All other luminaire test values shall be stated at 25°C.

Waterford City and County Council reserve the right to review *LM80* reports for the chipset used within the luminaire, and *luminaire thermal test reports* before permitting their use.

- 5.17 Lighting designers undertaking sports lighting projects shall design to the appropriate sport and competition level as detailed in *I.S. EN 12193:2007 Light and Lighting - Sports Lighting*. Particular attention shall be given to restricting light trespass onto neighbouring properties and to reducing 'skyglow'. The levels provided in *Table 1 of 5.10 Obtrusive Light* in *I.S. EN 12193: 2007* shall not be exceeded. Further guidance on the control of light trespass and pollution is available from both *The Institution of Lighting Professionals* and from *The Society of Light and Lighting*.
- 5.18 Illuminated bollards shall not be used.
- 5.19 Ground recessed flood lights shall not be used, unless in exceptional circumstances, and only with the pre-approval of Waterford City and County Council.
- 5.20 Pedestrian and cycle routes that link areas, or form parts of overall routes shall be illuminated in line with the lighting levels planned in the area. Pedestrian routes that are by their nature for amenity should not be illuminated.

6 Lighting Design for Upgrade Projects

No changes may be made to existing lighting infrastructure owned or operated in any way by Waterford City and County Council without the permission of an appropriate local authority staff member.

No upgrade or luminaire replacement may take place without a lighting design having been completed by a competent lighting designer and approved by Waterford City and County Council.

The lighting design process for upgrade and renewal projects shall follow the same rules as detailed in section 5 above with additional steps as follows:

- 6.1 An aboveground site survey shall be undertaken. The survey shall record the following information and be provided to Waterford City and County Council.
- 6.1.1 A geo referenced drawing showing the lighting column, customer



supply cabinets, midi pillars and cable access chambers. These locations shall be recorded with at least 1m accuracy.

6.1.2 The geo location and direction of any overhead power lines close to the intended lighting installation, where the public lighting will be installed by any method other than on distribution network poles. These locations shall be recorded with at least 1m accuracy.

6.1.3 A spreadsheet shall be produced showing:

- Column or network pole type.
- Column height.
- Bracket details, including inclination, outreach and uplift dimensions.
- Luminaire lamp type i.e. SON or SOX.
- The visual condition of the pole or column and any bracket.
- The presence or absence of an interface box on network poles.
- The height and orientation of column doors.
- Any issues regarding column siting, particularly regarding setbacks.
- Any column or service cabinet that is overgrown.
- Any detail that may affect the safe use or retention of the network pole, column, bracket or service cabinet.
- Any detail that may affect the safety of people in the area.
- Any defect that is recognised during the survey as a hazard should be reported immediately to Waterford City and County Council, providing as much information regarding the defect and the equipment location as possible.

6.2 A lighting classification shall be determined as detailed in 5.3 above. This classification shall be based on the current usage of the road. Regard shall be given to adjoining lighting levels to ensure lighting levels remain within two steps of each other. If the steps in classifications are greater than two, transition zones will be required.

7 Lighting Carparks

The lighting levels for carparks shall be selected from *Table 5.9* in *I.S. EN 12464-2:2007* (CEN/CENELEC, 2006) and care shall be taken to select the appropriate classification based on vehicular movements rather than the size of the carpark.

Care shall be taken to ensure that light sources are arranged to prevent glare to the car park users, and to minimise nuisance light to neighbouring properties.

8 Dimming

Dimming shall be considered for each lighting design, regardless of the application. The designer shall consider the dimming amount along with the hours of dimming, which should be based on the needs of the user, the location and the nature of the area being illuminated. Lighting in areas where there is a risk of anti-social behaviour shall not be dimmed, and the intention not to dim be approved in writing with Waterford City and County Council.

While the current unmetered tariffs specify dimming percentiles, it should not be taken that dimming by those percentages is appropriate. All designs with a dimming element shall have lighting level calculations showing the achieved lighting levels after dimming.

There are several dimming profiles available, a selection of which are shown in *Figure 1*.

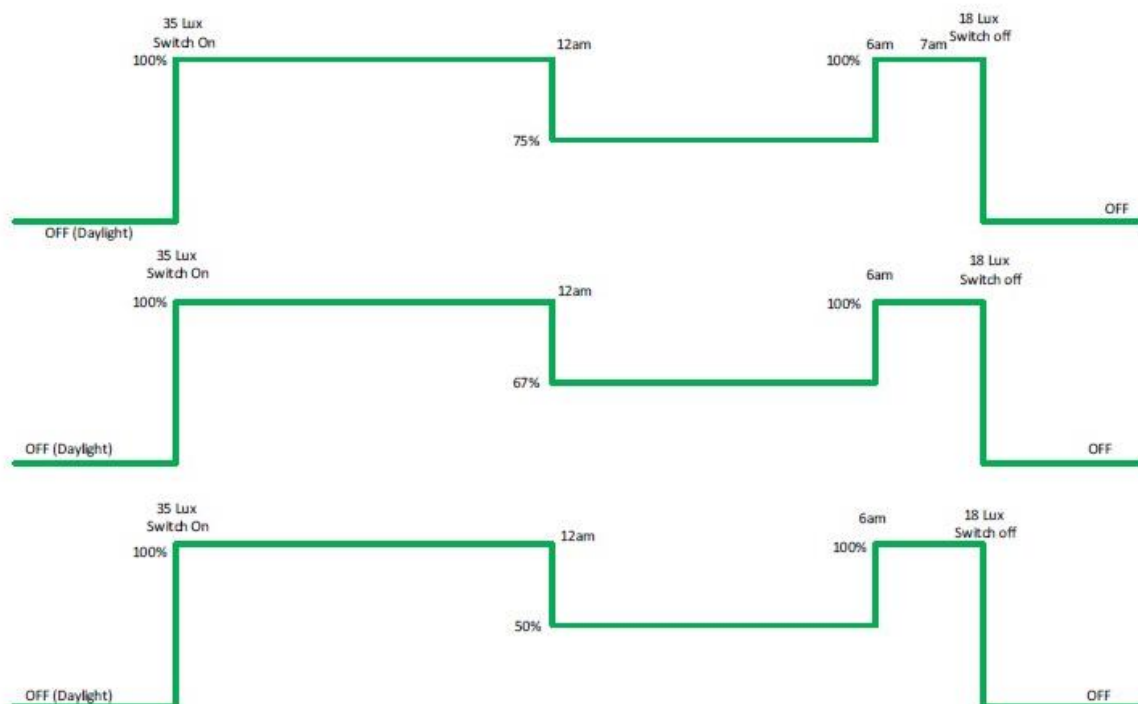

Figure 1: Dimming Profiles

8.1 Dimming Luminance Lighting

Dimming of traffic route lighting shall be done in steps of lighting classes i.e. *M4* dimmed to *M5* in line with the reduction in traffic flow. Care shall be taken that dimming of the lighting does not create steps in lighting classes greater than two with any surrounding lighting. Transition zones will be used if steps between lighting classes are greater than two.

The lighting design calculation shall show the lighting level at full output and for each dimming step included in the design. The designer shall state the lighting classification complied with for each step. The lighting classification type shall remain constant during the dimming regime, for example, an *M* classification at full power shall be retained during all stages of dimming, only the luminous intensities may change.

8.2 Dimming Illuminance Lighting

The dimming profile and hours dimmed may vary with the nature and location that is being illuminated. Care shall be taken that dimming of the lighting does not create steps in lighting classes greater than two with any surrounding lighting. Transition zones will be used if steps between lighting classes are greater than two.

- 8.2.1 The dimming regime on traffic route conflict areas shall match the main traffic route lighting dimming regime and shall always remain one class above the main traffic route lighting. The lighting design calculation shall be replicated to show each dimming class and state the lighting classification achieved.
- 8.2.2 Any dimming of standalone conflict zones shall be done in steps of classification level. Care shall be taken that dimming of the lighting does not create steps in lighting classes greater than two classes with any surrounding lighting. Transition zones will be used if steps between lighting



classes are greater than two. The lighting design calculation shall be replicated to show each dimming class and state the lighting classification achieved.

8.2.3 Dimming of residential estates shall be by 25% (profile U14) and the dimming hours shall match the dimming profiles detailed in Appendix H. Dimming by 25% from 00:00 to 06:00 shall be applied to all residential lighting projects. However, should the designer's risk assessment find that dimming is not appropriate, this shall be agreed in writing with Waterford City and County Council.

8.2.4 Use of dynamic lighting systems in residential areas shall not be used as the switching of luminaires in such locations can lead to sleep disruption for people living in the vicinity.

8.3 Dimming Lighting in Amenity Areas

Certain areas lend themselves well to lighting controlled by sensors. The sensor control can be used to detect pedestrians and either turn on luminaires or ramp up dimmed luminaires to full output. The designer shall carefully select the times when luminaires are switching and/or dimming so as the dynamic lighting does not become a nuisance to neighbours. Areas that could be illuminated in such a manner include, walkways and cycle paths in parks or residential areas, walking paths around sports pitches, some car parks and some types of industrial or commercial sites. The lighting design calculation shall be replicated to show each dimming class and state the lighting classification achieved.

8.4 Dimming Lighting in Surface Carparks

Hours of access shall be considered when dimming lighting levels in carparks. If the car park is in use throughout the night, then dimming below 5.9.1 from *I.S EN 12464-2:2007* shall not be considered. If access is not permitted, then the lighting may be dimmed to a level sufficient for security or turned off completely.

For surface carparks illuminated to higher lighting levels, then dimming shall be in steps to ensure compliance with a lower, appropriate lighting class derived from *I.S EN 12464-2:2007* 5.9. (CEN/CENELEC, 2006).

9 Light Source Temperature CCT

Generally, light sources with a CCT in the order of 3,000K shall be used in residential applications and in the order of 4,000K in all other applications.

For flood lighting applications and lighting in the vicinity of historical features, then a source colour shall be selected after testing on site and with the approval of Waterford City and County Council.

Light source colour temperature should not be selected on its own as a method of protecting wildlife.

10 Design Approval

10.1 All lighting, lighting infrastructure and electrical designs must be approved in writing by the Roads Department of Waterford City and County Council before any associated works commence on site.



10.2 The design approval system is a simple pass or fail process and is designed to encourage sustainable, energy efficient lighting solutions, utilising appropriate modern equipment and technology.

10.3 Waterford City and County Council provides a check list for designers to complete and submit with their design for approval, shown in *Addendum 1*. The list should be completed along with the required supporting documents. Incomplete submissions will not be approved.

10.4 All exterior lighting and associated electrical infrastructure must be submitted in the following format:

10.4.1 Lighting Reality® (or approved alternative) calculations in soft format. The cover shall show:

- The identity of the lighting designer, both the individual and the company.
- The name of the project.
- The lighting classification designed to at full power, and a second calculation reflecting the designed dimming.
- The combined maintenance factor for the luminaire and how it was derived.
- The ambient temperature of the photometry used.

10.4.2 Lighting Reality® (or approved equivalent) report in PDF format.

10.4.3 CAD drawing in soft format showing the following information:

- The site boundary.
- All landscaping details.
- All services.
- All private areas to be hatched and identified.
- Individually numbered columns with icons of a size to allow accurate assessment of the column positions.
- PL ducting layout.
- PL cable access chambers.
- Individually numbered public lighting midi pillar locations.
- ESB cabinet locations.
- Individually numbered single line circuit diagrams.
- All duct, column foundation or any other detail shall only show Waterford City and County Council approved versions. Non-approved versions shall not be included in any drawing submitted to contractors.

10.4.4 Technical specifications for the proposed equipment, and if requested, *luminaire thermal test reports* and *LM80* reports.



- 10.4.5 Written details outlining the OEM warranty and the procedure for transferring warranty to Waterford City and County Council when the development is presented for taken in charge.
- 10.4.6 Electrical cable calculations for each circuit.
- 10.4.7 Energy consumption calculations reflecting any designed dimming regime.
- 10.5 The substitution of *PDF* type files over requested soft copy versions prevent Waterford City and County Council from fulfilling their statutory duties detailed in *S.I. 291* and are therefore not acceptable.
- 10.6 Work shall not commence on site until after approval for the design has been granted by Waterford City and County Council.
- 10.7 Any revisions or alterations to the approved lighting design must be submitted to Waterford City and County Council for approval before being undertaken on site.

11 Electrical Connection

- 11.1 Electrical loads for public lighting shall be designed so that a single-phase supply is sufficient and must not exceed 2kVA per connection point, so as to allow an unmetered connection to the electrical distribution network.

For larger transport infrastructure, a metered supply will be considered. The designer shall gain approval from Waterford City and County Council prior to completing the metered electrical design.

- 11.2 Full and complete electrical cable calculations shall be provided for each circuit. Provision shall be made in the calculation to allow for *constant lumen output* luminaires at 100,000 hours. The total kVA for each midi pillar shall be stated.
- 11.3 All electrical supply circuits shall be sized for an additional 25% for future expansion.
- 11.4 In all cases, the developer is responsible for arranging and carrying out the connection to the electrical distribution system.
- 11.5 It is the developer's responsibility to ensure the installation meets all electrical safety requirements and is certified to *ETCI* regulations.
- 11.6 The developer must maintain the installation and pay all electrical bills prior to being taken in charge.
- 11.7 The developer will be liable for all costs associated in making good any faults found during the pre-taking in charge inspection.
- 11.8 No changes shall be made to existing public lighting electrical infrastructure owned or operated in any way by Waterford City and County Council, without the express permission of an appropriate council staff member.

12 Protection of Flora and Fauna

Waterford City and County Council rightly values the diverse wildlife which exists throughout the urban, rural and coastal regions. Much of this delicate eco structure is protected by national and international laws and as such, cannot be interfered with.



While research into the effects of light, and types of light is still ongoing, it is agreed that the strip of light evident in street lighting is in effect, a barrier to many species, regardless of the colour temperature of the light source. This includes, but is not limited to nesting areas, bat roosts, bat hunting areas, bat commuting routes, rivers, spawning grounds, and other such locals.

It is the developer's duty to ensure that any lighting installation will not interfere in any way with protected, or endangered species or their habitats.

Conclusion

Waterford City and County Council believes that adhering to the standards and specifications identified in this document will result in a sustainable and energy efficient lighting infrastructure that brings value and security to residents and the general public using amenities in the county.

The energy efficiency measures stipulated will greatly assist in meeting the European Communities' energy efficiency targets for 2020 and the planned targets for 2030, as well as meeting the statutory requirements defined in the *European Union (Energy Efficiency) Regulations 2014* (Department of Communications, Energy and Natural Resources, 2014).

Please contact us if there is any aspect of Waterford City and County Council's public lighting strategy that requires clarification.



References

British Standards Institute , 2010. *BS 7654:2010. Specification for single-phase street lighting cut-out assemblies for low-voltage public electricity distribution systems. 25 A rating for highway power supplies and street furniture.* London: British Standards Institute.

British Standards Institute , 2013. *BS EN 60529:1992+A2:2013. Degrees of protection provided by enclosures (IP code).* London: British Standards Institute.

British Standards Institute, 2002. *BS EN 62262:2002. Degrees of protection provided by enclosures for electrical equipment against external mechanical impacts (IK code).* London: British Standards Institute.

British Standards Institute, 2010. *BS 7657:2010. Specification for cut-out assemblies up to 100 A rating, for power supply to buildings.* London: British Standards Institute.

British Standards Institute, 2012. *BS 5489-1:2013 Code of practice for the design of road lighting Part 1: Lighting of roads and public amenity areas..* Seventh ed. London: s.n.

British Standards Institute, 2013. *BS EN 40-3-1:2013. Lighting columns. Design and verification. Specification for characteristic loads.* London: British Standards Institute.

British Standards Institute, 2013. *Low-voltage fuses. Supplementary requirements for fuses for use by authorized persons (fuses mainly for industrial application). Examples of standardized systems of fuses A to K BS HD 60269-2:2013, BS 88-2:2013.* London: British Standards Institute.

CEN/CENELEC, 2006. *I.S. EN 12464-2:2007 Lighting of Work Places - Part 2: Outdoor work Places.* Dublin: National Standards Authority Ireland.

CEN/CENELEC, 2015. *I.S. EN 13201 - 5: 2015 Road Lighting - Part 5: Energy performance Indicators.* Dublin: National Standards Authority Ireland.

CEN/CENELEC, 2015. *I.S. EN 13201 - 5:2015.* Dublin: National Standards Authority Ireland.

CEN/CENELEC, 2015. *Road Lighting - Part 1: Guidelines on selection of lighting classes.* Updated May 2016 ed. Dublin: National Standards Authority of Ireland.

CEN/CENELEC, 2016. *I.S. EN 13201-2:2015.* Dublin: National Standards Authority Ireland.

Department of Communications, Energy and Natural Resources, 2014. *The European Union (Energy Efficiency) Regulations 2014 S.I. No 426 of 2014.* Dublin: The Stationary Office.

Department of Enterprise, Trade and Employment, 2007. *S.I. No 299 of 2007 Safety, Health and Welfare at Work (General Applications) Regulations 2007.* Dublin: The Stationary Office.

Department of Jobs, Enterprise and Innovation, 2013. *S.I. 291 Safety, Health and Welfare at Work (Construction) Regulations 2013.* Dublin: The Stationary Office.

Electro-Technical Council of Ireland, 2016. *National Rules for Electrical Installations.* Fourth Edition ed. Dublin: Electro-Technical Council of Ireland.

ESB Networks, 2019. *Code of Practise for Avoiding Danger from Overhead Electricity Lines.* Second ed. Dublin: s.n.

ESBN, 2008. *National Code of Practise for Customer Interface.* 4 ed. Dublin: ESBN.

European Committee for Electrotechnical Standardisation , 2009. *BS EN 60598-1:2008. Luminaires . General requirements and tests.* London: British Standards Institute.

Health and Safety Authority, 2016. *Code of Practise for Avoiding Danger from Underground Services.* Dublin: Health and Safety Authority.

International Organisation for Standardisation, 2015. *EN 1461 2009. Hot dip galvanized coatings on fabricated iron and steel articles -- Specifications and test methods.* Dublin: National Standards Authority of Ireland.



National Standards Authority of Ireland, 2015. *I.S. EN ISO 9001: 2015. Quality Management Systems - Requirements*. Dublin: National Standards Authority of Ireland.

Appendix A Cable and Ducting Specification

- A.1 All cables are to be installed in ducting. Ducting shall not run through, or below private property.
- A.2 No jointing of cables will be accepted in any circumstances.
- A.3 Three core *XLPE/SWA/PVC* must be used throughout the installation, size to be selected by appropriate calculations, but a minimum of 6mm² shall be used.
- A.4 Ducts must be single walled, colour red, high density polyethylene (H.D.P.E.). The duct shall have a nominal 100mm diameter. For runs shorter than 1m, flexible duct of 50mm is acceptable.

The duct must have the words "Public Lighting" stamped at 1m intervals. The letters must be 9mm in height.

- A.5 Ducting shall be laid in fully coupled unbroken lengths and shall run directly between the column pots and/or midi pillar. Draw wires must be provided at all termination points.

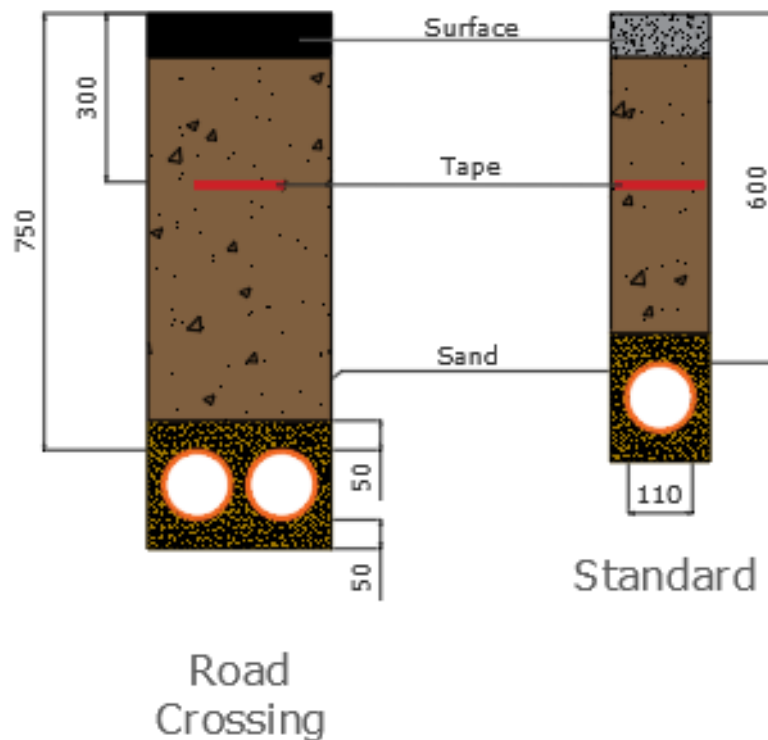

Figure 2: Road crossing duct detail

Ducting shall be laid to the appropriate depth as mandated by *ETCI* regulations and surrounded by sand before burying with appropriate material as shown in *figures 1 and 2*.

All ducts shall be marked with electrical marking tape at 300mm below finished ground level.

Draw wires of at least 8kN must be provided at all termination points.



- A.6 Cable access chambers shall be provided where ducts take acute turns, or in any instance where they cross beneath any surface used by vehicles, including any shared surfaces.
- A.7 At road crossings and under shared surfaces such as *Homezones*, spare ducting shall be provided. Ducting setback in relation to road edge will vary depending on the set back of rooted lighting columns.
- A.8 Ducting shall be properly coupled.

Appendix B Cable Access Chamber Specification

- B.1 Access chambers must be provided at all access points for road crossings, acute bends in duct runs, duct junctions, and under shared surfaces and *Homezone* surfaces.

Access chambers shall only be installed in *Group 2* areas suitable for loading class i.e. *C250* in footways, pedestrian areas and comparable areas. *D400* to be used at all trafficked locations.

Chambers shall be deep enough that ducts shall not rise or fall on their approach.

- B.2 At road crossings and under shared surfaces spare ducting shall be provided. Ducting setback in relation to road edge will vary depending on the set back of rooted lighting columns. Spare ducts shall run between access chambers under road crossings and shared surfaces and *Homezone* surfaces.
- B.3 Access chambers shall be 450mm square as a minimum. Larger sizes may be required when numerous public lighting supply cables pass through, or where the maximum bend radii of the cables demand a larger area.
- B.4 High strength engineering bricks or cast in situ concrete or standard concrete blocks shall be used to construct the manhole chambers directly under the cover and frame. Pre-fabricated chamber boxes shall not be used.
- B.5 The chamber cover manufacturer shall be registered with and certified by either *NSAI, British Standards Institute of Quality Assurance Services* or *Lloyds Register Quality Assurance Register* for the design, manufacture, supply and verification of chamber covers under their quality assessment schedule to *ISO 9001* (National Standards Authority of Ireland, 2015).
- B.6 The cover shall be lockable in place. There shall be provision for replacements of bolt and nut if damaged.

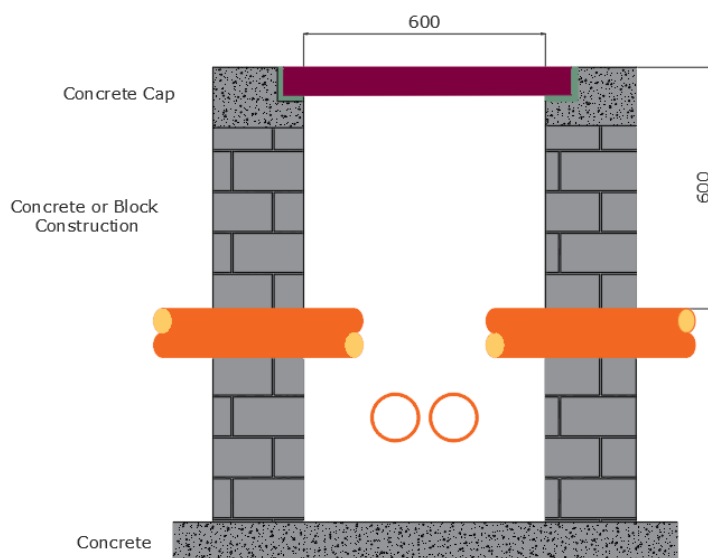

Figure 3: Cable access chamber

Appendix C Column and Bracket Specification

- C.1 All columns shall be of the same type within any one scheme. Tubular or octagonal steel columns which comply are acceptable and shall be protected against corrosion by hot-dip galvanising to *ISO EN 1461* (International Organisation for Standardisation, 2015).

Bespoke or decorative columns will only be permitted by prior agreement with the Senior Executive Engineer in the Roads Department of Waterford City and County Council.

- C.2 All lighting columns shall be designed to the *EN 40* and in accordance with *BD94/07* (British Standards Institute, 2013) for a minimum 25 year life for a *Terrain Category* of TC3 and reference the relevant 10 minute mean wind velocity.

Column specification and associated windage calculations must include for a 1.5m square sign and assume a 1.5m bracket length, even where the current design does not call for a sign or bracket.

- C.3 The lighting column manufacturer shall be registered with and certified by either *NSAI, British Standards Institute of Quality Assurance Services* or *Lloyds Register Quality Assurance Register* for the design, manufacture, supply and verification of road lighting columns and brackets under their quality assessment schedule to *ISO 9001* (National Standards Authority of Ireland, 2015).

The quality assurance certification shall relate to the specific lighting column material being proposed. Waterford City and County Council reserves the right to request proof of certification from the proposed column manufacturer.

- C.4 All octagonal columns must be fabricated with longitudinal welding only.

All tubular columns must incorporate an anti-rotational device.

- C.5 A vertical cable entry slot with smooth edges, rounded at top and bottom and measuring 150mm X 75mm shall be provided in the column root. The entry slot shall be in line with the column door opening. The top of the entry slot shall be at 300mm below ground level as shown in *figure 4*.

A bituminous coating to a level 250mm above finished ground level shall protect the planted portion and above of both the inside and outside of each column.

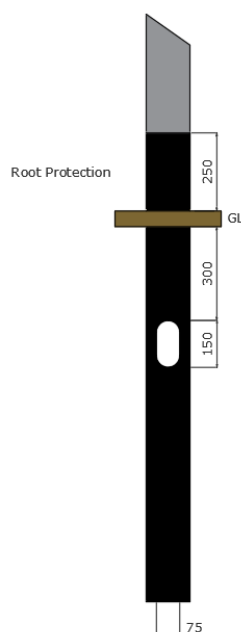

Figure 4: Cable slot detail

- C.6 For octagonal columns, the door opening shall have a welded-in frame with an all-round weather strip. A flat steel door of minimum thickness 3mm secured by two triangular head bolts shall be fitted.

For all other columns, the door opening shall be plasma cut. Twin bolts shall be used. Receiving sockets shall be adjustable using non-corrosive materials to allow for interchangeable doors.



The locking triangular head bolts shall have a narrow neck under the head to take a retaining washer. The bolt threads shall be lightly greased to prevent seizing or binding. Bolts must be secured to an 8mm nut welded in place.

Nuts held by compression or clipped in place shall not be accepted.

- C.7 All doors shall be of a standard size and be fully interchangeable. They shall not require any site adjustment or modification to fit each column properly. They shall be a minimum of 385mm x 90mm.

- C.8 A baseboard, with a minimum working area equal to the door opening, shall be fitted in each column and shall be treated with intumescent varnish to prevent fire propagation.

The clearance between baseboard and inside face of door when secured shall not be less than 100mm. The baseboard must be capable of being removed and replaced. Baseboard fixings shall be recessed below the surface of the board so as not to impede the fixing of electrical equipment to the baseboard. An earth terminal shall be provided in a readily accessible position at the bottom of the opening.

- C.9 Columns located in areas inaccessible to standard maintenance equipment must be base-hinged columns as manufactured by Abacus Lighting or approved equivalent. Gear must be accessible by lowering the column only.

All base hinged columns must be delivered with a standard anti-vandal locking screw as standard.

The base hinged column must only be capable of being lowered with a universal lever.

- C.10 Where columns are to be installed into parks and green spaces and hinged columns are deemed inappropriate, vehicular access must be provided for maintenance actions. The minimum paved width required for the maintenance truck fitted with a hoist is 3.5m. The paved width shall be laid out in such a manner that the maintenance vehicle does not have to reverse to egress the area.

The paved path must have sufficient structural strength to support the weight of the truck and the pressure of the truck stabilisers without incurring damage.

- C.11 The use of outreach brackets on new installations is usually not necessary and should only be used where installation geometry is challenging. Columns shall be fitted with a spigot to suit the selected design luminaire.

Where outreach brackets are required for lighting performance reasons, both the columns and brackets assemblies shall conform to the deflection requirements of *Class 2* as defined in *IS EN 40-3-3* (British Standards Institute, 2013).

- C.12 The removable bracket arms for the columns shall be of steel construction and protected against corrosion by hot dip galvanising to *BS EN 1461* (International Organisation for Standardisation, 2015).

Bracket arms and column shaft shall be of the sleeve fitting type, with the bracket fitting snugly over the column.

- C.13 For tubular columns, the bracket shall be secured by eight hexagonal headed stainless steel screws, minimum diameter 8mm. Brackets used for columns greater than 8 metres must have 8mm nuts welded to the outer face of the bracket wall to enable secure fixing.

- C.14 Where there are shared surfaces, the designer must design out the risk presented by columns. If this cannot be achieved, passive safe columns along with electrical disconnect systems of an appropriate type shall be used. The designer must consult with Waterford City and County Council and approval granted before the system is specified.

Appendix D Supply Cabinet Specification

- D.1 Customer supply pillars shall be installed in land that is open to the public and never on private property.

ESB customer service pillars and midi pillars shall be installed a minimum of two metres apart as shown in *figure 5*. If this is not physically possible and only with the explicit permission of ESB Networks and Waterford City and County Council Public Lighting Section these may be installed closer together and equi-potentially bonded in accordance to *ET101* (Electro-Technical Council of Ireland, 2016).

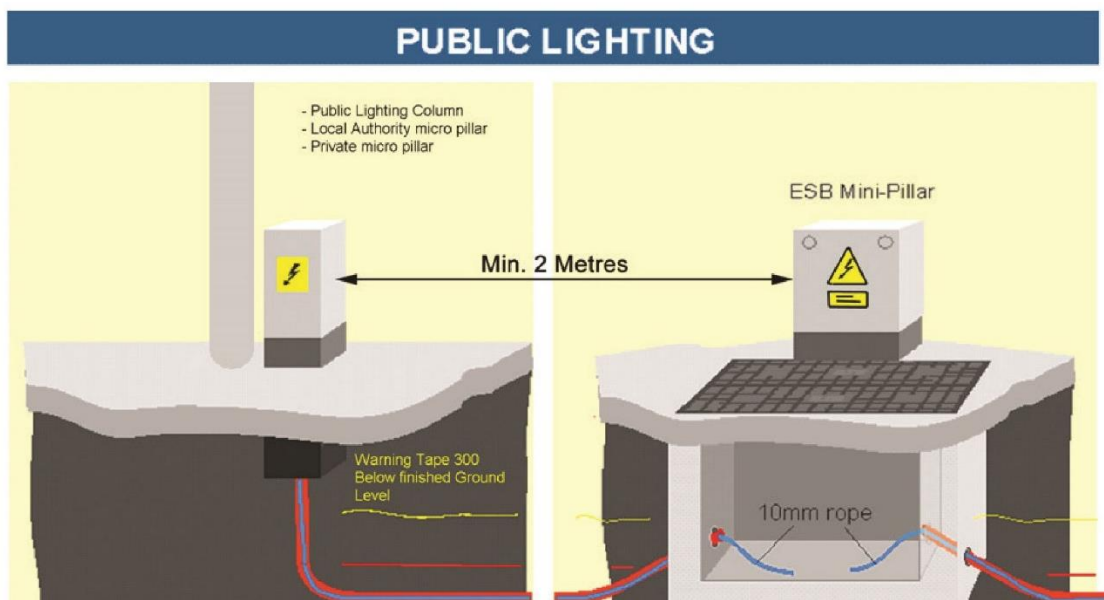

Figure 5: Pillar spacing

- D.2 Earthing for the customer service pillar should be in accordance with the *ESB National Code of Practice for Customer Interface 4th edition 2008*.
- D.3 The midi pillar (customer unmetered supply pillar) shall have typical dimensions of 150mm x 250mm x 600mm. Extension plates, or root assembly, typically 320mm deep shall be fitted at the bottom to enable firm cementing into the ground. Photographic evidence of correct installation shall be provided for each midi pillar and be available if requested by Waterford City and County Council.
- The extension plate, including the planted portion below ground and 50mm of the above ground shall be protected by a bitumous coating.
- D.4 The midi pillar shall be fitted with a single flat plate door nominally 220mm wide x 510mm high, with a triangular, captive head locking bolt.
- D.5 The midi pillar shall be vented. The venting shall be such that it protects against direct ingress of rain.
- D.6 The midi pillar shall be protected against corrosion by hot dip galvanising in accordance with *BS EN 1461* (International Organisation for Standardisation, 2015) and shall be properly vented.
- A baseboard, approximately 20mm thick and treated with intumescent varnish shall be mounted in each pillar.
- D.7 All supply pillars shall have a high voltage symbol attached to the front panel.
- D.8 The main over current protective device shall be provided by a 32 amp rated high rupturing capacity type cut-out with a minimum rupturing capacity (short circuit level) of no less than

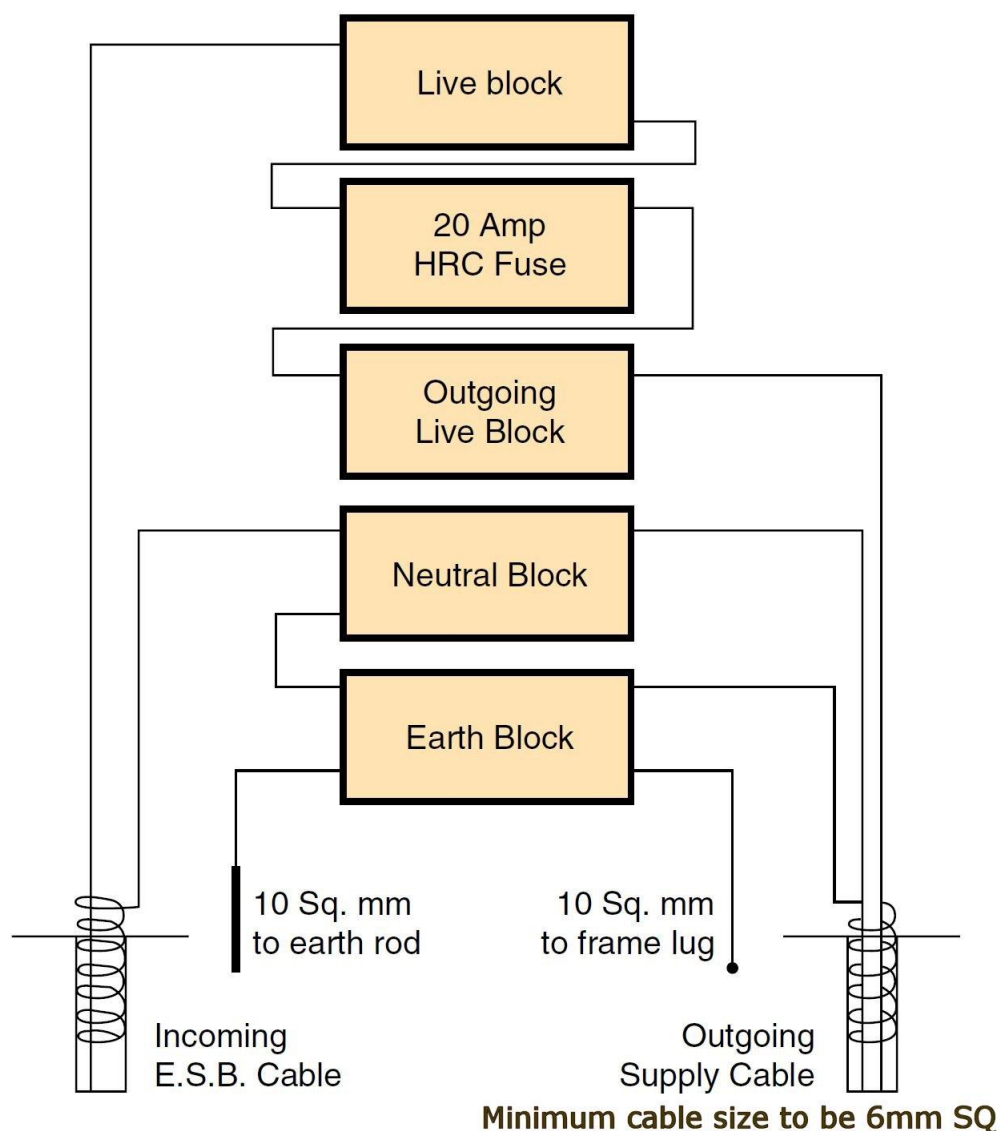

Figure 6: Midi pillar electrical schematic

- D.9 Each outgoing circuit shall be individually fused by means of a 20A HRC cut-out type fuse.
- D.10 The live contacts of all fuse bases should be shrouded so accidental contact with live metal cannot be made when the fuse carrier is withdrawn. Terminals shall have a serrated bore to ensure good contact with all types of conductors. The use of M.C.B.'s shall not be accepted in public lighting columns or pillars.
- D.11 Each midi pillar must be earthed using an earth rod and the supply neutralised. The earth rod shall be either a bare copper or hot dipped galvanised iron pipe or rod of at least 16mm diameter. It shall be driven vertically into the soil for a length of not less than 1.2m.

If ground conditions do not allow driving an earth rod, then a horizontal earth electrode can be used. It shall consist of 4.5m of bare copper or galvanised iron rod of 16mm diameter,



or at least 4.5m of bare copper or galvanised steel wire of at least 25mm² cross sectional area buried in the soil at least 500mm deep.

In certain ground conditions, *ESB Networks* may require additional earth procedures. Developers should check with *ESB Networks* to confirm their requirements.

- D.12 Evidence of the correct installation of the earth rod may be requested by Waterford City and County Council. The developer and/or the contractor should keep photographic, referenced records of the earth rod installation.
- D.13 A main earth terminal shall be mounted on the midi pillar baseboard, to which the following will be connected:
- D13.1 6mm² PVC cable from the earth terminal on the pillar. A crimped lug shall be used for the connection to the pillar.
 - D13.2 10mm² PVC cable from the earth electrode.
 - D13.3 6mm² PVC cable from the neutral link.
- D.14 The earthing lead to the earthing electrode shall exit the pillar via the service cable entry opening. The earth electrode connection shall be:
- D14.1 Enclosed in a galvanized steel box of 100mm³ approximately, with an inspection cover.
 - D14.2 Protected against corrosion by a suitable weatherproof tape.
 - D14.3 All to be buried underground after inspection to avoid damage by vandals.

Appendix E Column Installation

- E.1 All columns shall be installed and oriented so that the access door faces away from oncoming traffic as shown in *figure 7*.

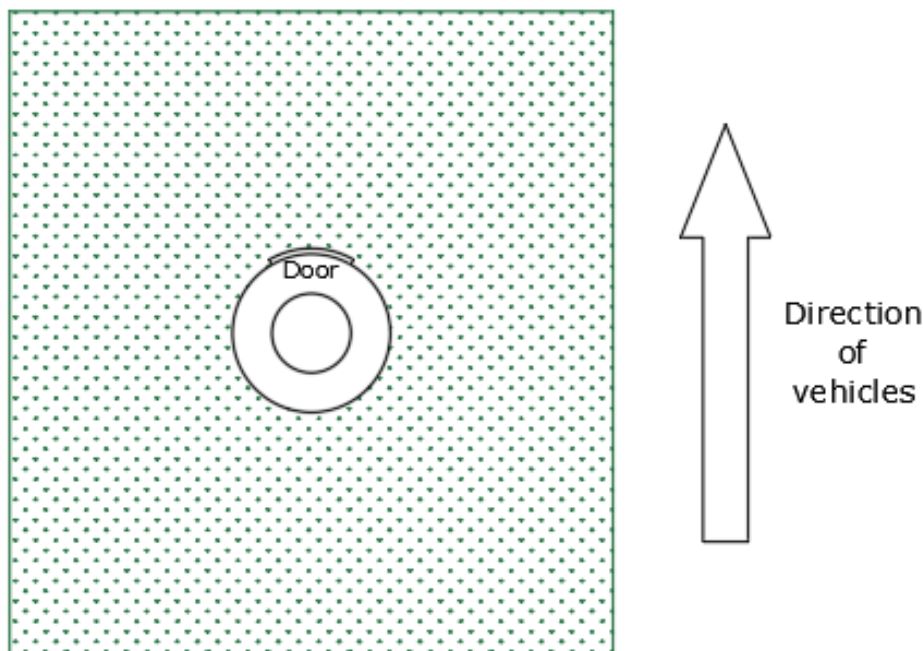

Figure 7: Door positioning

- Columns must be erected securely and vertically in the exact positions indicated in the design drawings. Columns found to be in positions other than design locations, unless previously agreed with Waterford City and County Council must be relocated to the design positions.
- E.2 Where columns are to be situated in the vicinity of overhead high tension cables, approval must be sought from the *ESBI Design Office* as to the exclusion zone with regards to the intended column height. Proof of this approval will be sought by Waterford City and County Council prior to taking in charge.
- E.3 Columns are to be installed in line with the recommended minimum clearances from the edge of the carriageway to the face of the lighting columns in *4.3.3.3 Table 2 of BS5489; 2013* (British Standards Institute, 2012).
- E.4 Columns shall be erected in line with the recommendations of *EN40-1* (British Standards Institute, 2013) regarding planting depths of columns. The contractor shall confirm with the column manufacturer/supplier the recommended depth for the root of the proposed columns.
- E.5 Columns shall be erected by planting their root portions in excavation of suitable size and secured. The excavated hole shall be pumped free of water prior to any filling with concrete.
- E.6 Where sleeves are used, they must have an outside diameter of 400mm minimum for 6m columns. This size may increase with increasing column base widths. Sleeves shall be installed such that the top of the sleeve finishes below the cable entry slot. Sleeves must be of a ridged construction.
- E.7 Where the rooting depths to *EN40-1* (British Standards Institute, 2013) are unachievable due to existing services or ground conditions, flange mounted columns may be used only with the prior written approval of Waterford City and County Council.

Where flanges are approved for use they must comply with *EN40-1* (British Standards Institute, 2013).

A full set of design calculations for the structural base for the mounting of the flange, shall be undertaken by a competent person and must be submitted for Waterford City and County Council records.

E.8 All columns shall be set such that the centre of the column door is 1.5m above the finished ground level as shown in *figure 8*.

E.9 Close electrical protection of the column shall be provided by a 25A rated cut-out loaded with a 6A fuse incorporating a *cam lever* single pole disconnection. The cut-out will use a separate neutral and earth.

The cut-out must provide ingress protection to *IP 21* as defined by *EN 60529* (British Standards Institute , 2013).

Residual circuit devices or miniature circuit breakers shall not be used.

E.10 The column shall be earthed from the incoming cable via a 6mm² PVC cable which will be connected to the column by a crimped lug.

E.11 All columns shall have a switch fitted for testing purposes that bypasses the luminaire PECU. The switch shall be mounted securely on the column baseboard. The switch shall be 5 Amp rated and be protected to *IP42* (British Standards Institute , 2013).

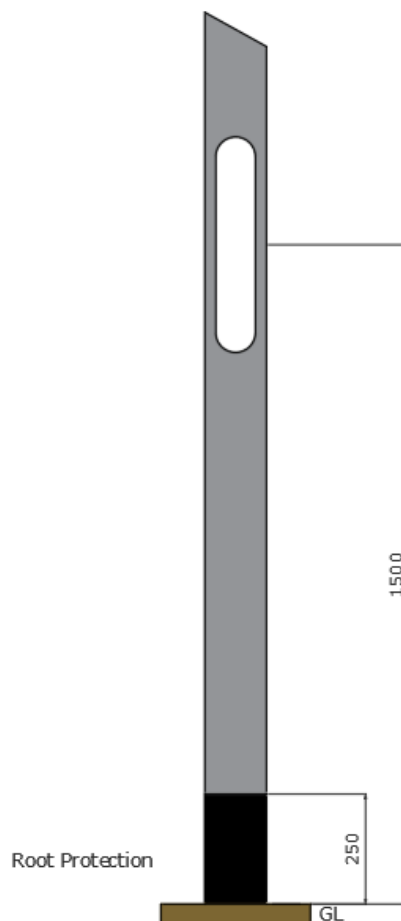

Figure 8: Column door height.

E.12 All components required for connection shall be firmly fixed to the column back board in a tidy and professional manner.

All conductors shall be stripped to the appropriate length to allow for connection. No exposed conductors shall be allowed.

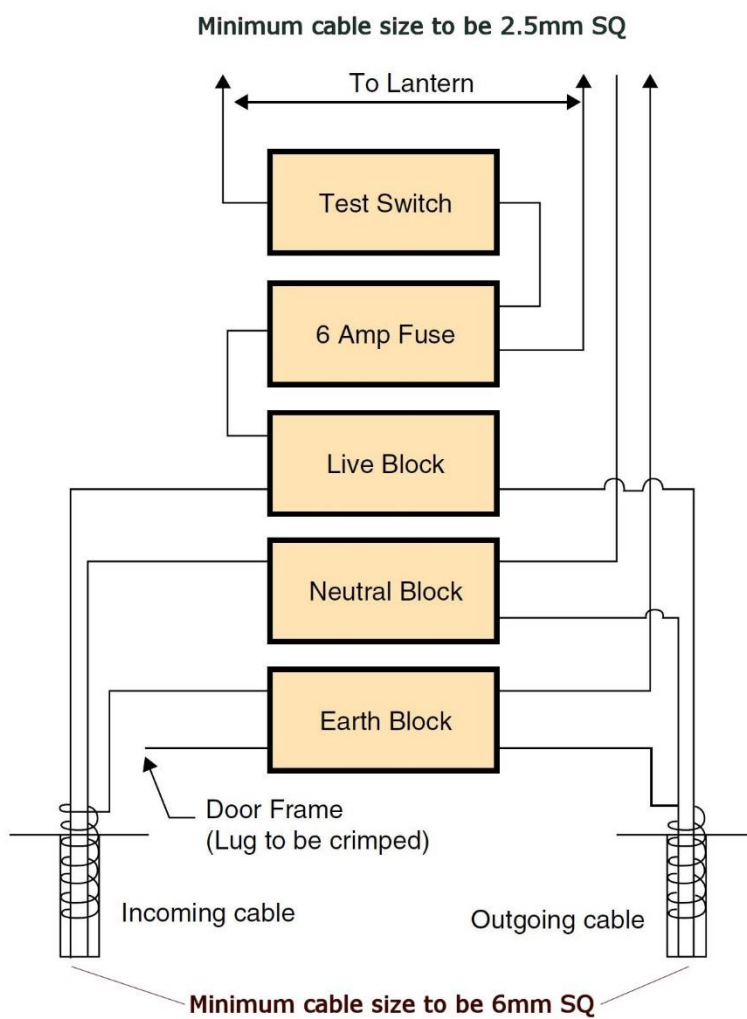

Figure 9: Column Electrical Schematic



Appendix F Electrical Design

F.1 The electrical services design for the scheme shall be undertaken to comply with the relevant sections of *ETCI National Rules*. In particular the requirements set out in section 714 of *ET 101: 2008* (Electro-Technical Council of Ireland, 2016).

F.2 A detailed cable design shall be undertaken to match the calculated electrical load which would typically allow up to nine luminaires to be supplied per phase. An additional capacity of 25% shall be included for future extensions.

The provision of earth loop/fault level calculations and circuit disconnection (fuse rupture times) shall be undertaken by the electrical contractor.

Public lighting schemes requiring cable lengths in excess of 200 meters require careful design to meet the earth loop impedance requirements of *ET 101: 2008* (Electro-Technical Council of Ireland, 2016).

F.3 It is the duty of the installation contractor to ensure that disconnection/fuse rupture times shall be in compliance with those set out in *ET 101: 2008* (Electro-Technical Council of Ireland, 2016).

F.4 The contractor shall be responsible for the planned installation meeting the requirements of the *National Rules for Electrical Installations*. In particular, that the maximum volt drop is not exceeded, that the equipment installed is of sufficient rating for the prospective fault current, that the disconnection time is satisfactory, that the cables are of satisfactory current carrying capacity for the load under running and starting conditions and that the protective devices discriminate fully.

F.5 Miniature Circuit Breakers (MCB's) shall not be used in columns or pillars.

F.6 The main supply point switch fuse shall be a *BS 88 HRC* (British Standards Institute, 2013) fuse rated appropriately to the number of downstream circuits.

F.7 The fuses and circuit breakers shall have a minimum rupture capacity of *16kA*. All outgoing circuits shall be individually fused by means of a *20A HRC* cut-out type fuse.

F.8 Space shall be allocated for the ESB supplied cut-out and isolator as per the *ESBN National Code of Practice for Customer Interface* (ESBN, 2008).

F.9 Close protection of street lighting lanterns to be provided by a *25A* rated cut-out loaded with a *6A* fuse incorporating a cam lever double pole disconnection rated to *IEC 60947*.

The cut-out shall comply with a minimum degree of protection of *IP21* internally and *IP42* (British Standards Institute, 2013) externally and be moulded in a material which conforms to *BS 7654* (British Standards Institute, 2010).

All terminals shall be formed from solid brass and be electroplated for temperature rise stability. Terminals shall have a serrated bore to ensure good contact with all types of conductors.

F.10 Switches for testing purposes shall be installed, either horizontally or vertically, in each public lighting column. These switches shall be so wired as to override the photoelectric cell during daylight hours.

The switches shall be *5A* rated and must clearly indicate the "ON/OFF" position.

Switches must have a minimum rating of *IP42* (British Standards Institute, 2013).

Switches shall be securely mounted in an accessible position on the baseboard.

F.11 Connector (Link) blocks shall be used for the termination of all conductors of underground cables in columns. The Connector blocks shall conform to *BS 7657:2010* (British Standards



Institute, 2010) and rated *100Amp* for use on live and neutral connections. Each block shall incorporate five serrated cable bores (terminals) each capable of accepting cable sizes up to 35mm². The metal terminal block shall remain captured within its moulding when the cover is removed.

Connector blocks shall be solidly mounted on the column baseboards. Conductors shall not share the same terminal where spare ways are available in a connector block.

- F.12 Switching control of public lighting systems shall be achieved by means of photocell control. Each individual lantern shall be switched "ON" from dusk to dawn. 35_{LUX} switch on and 18_{LUX} switch off.
- F.13 The PECU shall be designed to fit the NEMA socket provided on each lantern.



Appendix G LED Luminaire Specification

- G.1 The luminaire shall be designed specifically to be used with LED light sources. It shall comply with all relevant EN standards and EC directives required by the CE *Community Marketing Directive*.
- G.2 Products must be tested in laboratories independently accredited to *EN 60598* and *ISO/IEC 17025*.
- Product quality and standard measurements will be based on *IEC/PAS 62717* and *IEC/PAS 62722*.
- Products must be designed to *EN 60598* (European Committee for Electrotechnical Standardisation, 2009) by organisations independently accredited to that standard.
- G.3 A *TM21* report must be provided as part of the design submission package.
- An *LM80* report must be supplied as part of the design submission package.
- G.4 The luminaire shall be supplied with surge protection of no less than 10kVa and shall be the first component in the luminaire's internal circuitry.
- G.5 The light source shall be modular and replaceable on site. The module should be fixed in such a way as to maximise heat transfer from the LED chip and its respective board.
- G.6 The LED colour temperature shall be appropriate to the application. Correlated Colour Index in the order of 4,000K, or 3,000K, depending on use.
- G.7 The optic assembly will be protected to *IP66* as defined by *EN 60529* (British Standards Institute, 2013)
- G.8 The lumen depreciation factor shall not exceed 0.9 at 100 000 hours at 25°C ambient. Luminaires that do not meet this requirement may be considered on an individual basis.
- G.9 The driver shall be housed in a dedicated, separate chamber within the lantern. The enclosure will be protected to a minimum of *IP65* as defined by *EN 60529* (British Standards Institute, 2013). The *IP* rating must be capable of being maintained throughout the design life of the lantern.
- G.10 The driver shall be *DALI* registered and capable of communication and interaction with a *CMS* communication module should it be required in the future.
- The manufacturer shall ensure that the driver is compatible with the LED array being used, and that the driver complies with all appropriate regulations, standards, quality criteria and directives.
- G.11 Drivers shall utilise *Constant Lumen Output* as standard. Energy consumption and connected load shall be based on the average load over the products design life.
- G.12 Drivers shall have over temperature protection and provide power factor correction of no less than 0.9.
- G.13 The luminaire shall be constructed from die cast aluminium and powder coated in grey. All coloured components of the luminaire shall be of the same colour code (*RAL*) and have the same visual appearance when viewed together.
- Other colours will be considered for decorative lighting applications.
- G.14 The luminaire will be constructed in a robust manner and be suitable to use in the intended application and location. The lantern shall have a minimum impact resistance of *IK08* (British Standards Institute, 2002).
- G.15 A signed declaration of conformity, along with certificates for ENC compliance and EMC



Directive compliance shall be provided. The equipment will be fully compliant with RoHS requirements.

- G.16 The weight and projected side area should be stated for the luminaire with all equipment and angle of installation considered in order to calculate column load.

The weight of the luminaire shall not exceed 15kg.

- G.17 Covers or openings on the luminaire required to be opened during the installation or maintenance of the light point must be captive when open.

All screws or fixtures required to be opened during installation or maintenance of the product must be protected against corrosion and seizure for the design life of the luminaire.

- G.18 LED failure fraction shall not be greater than 5% of the LEDs installed in the lantern over the design life of the lantern.

- G.19 The luminaire shall provide thermal protection for all its components to ensure the luminaire and its components operate within the stated temperature parameters through the design life of the lantern.

- G.20 Ambient temperature related to lantern performance and tests will be in the range of -35°C to +55°C. Lumen depreciation factor will be stated at 25°C.

- G.21 Electrical connection terminals shall be indelibly marked to indicate all wiring connections and use shrouded screws. Control equipment shall bear a clear circuit diagram in order to indicate all component connections in a concise manner.

An additional terminal will be required to enable overriding of the PECU by means of a 'line to test'.

- G.22 Operating voltages shall be clearly marked within the enclosure.

Electrical terminals shall be capable of terminating three core 2.5mm² flexible cable.

Any link cables, connector blocks and plug & socket arrangements must be of a suitable IP rating for their location and application and comply with all standards or directives.

- G.23 The complete luminaire including all component parts shall be guaranteed by the manufacturer for a minimum of ten years. Full written details of the warranty must be provided with the design submission.

A method statement defining how the warranty claims process should be accessed by Waterford City and County Council, or its agents, written by the manufacturer on the manufacturer's headed paper and signed by an identified director, must be provided with the design submission.

- G.24 Photometric performance, including lumen output used in designs shall be at an ambient temperature of 25°C. An *LM79* report shall be available if requested by Waterford City and County Council.

- G.25 Decorative luminaires will be considered individually, but they shall generally comply with the same requirements as a functional luminaire.

- G.26 Circuit Wattage (connected load) averaged for constant lumen output shall be stated for each luminaire variation proposed.

Drive current and power factor shall be stated for each luminaire variation proposed.

- G.27 The luminaire will be individually switched via a 7 pin NEMA socket, with all communication and power connections made at the time of assembly by the manufacturer.

A three pin PECU shall be used to switch the luminaire. The switch value shall be 35/18 lux.



Decorative luminaires shall utilise a miniature PECU with a 35/18 lux switching value. While the driver shall be enabled for dimming and communication via the *DALI* protocol, the communication cable shall not be connected.

G.28 All luminaires shall have an indelible manufacturing data label affixed inside the driver compartment, clearly visible without the need to remove components. The label shall show the following information:

- Manufacturer name.
- Model number/code.
- Date of manufacture.
- Batch number, if relevant.

G.29 All luminaires will be pre-wired by the manufacturer and shall not require opening by the contractor during installation.

The following cable sizes shall be used:

Up to 6m mounting ~ 1.5mm² 3 core *PVC/PVC*.

Over 6m mounting ~ 2.5mm² 3 core *PVC/PVC*.

G.30 The manufacturer shall provide the following information in accordance with the Lighting Industry Liaison Group's *A Guide to the Specification of LED Lighting Products*:

- Rated input power, identifying the amount of energy consumed by the lantern, including its power supply in Watts.
- Rated luminous flux in lumens in absolute photometric values. Absolute photometry results in a LOR=1.
- Lantern efficacy in lumens per Watt.
- Luminous intensity distribution.
- Correlated colour temperature in Kelvin.
- Rated colour rendering index (CRI).
- Rated chromaticity co-ordinate values. Initial and maintained.
- Maintained luminous flux.
- Rated life in hours of the LED module and the associated rated lumen maintenance.
- Failure fracture corresponding to the rated life of the LED module within the lantern.
- Ambient temperature for the lantern.



Appendix H Taking in Charge

- H.1 It is the developer's responsibility to ensure that the lighting infrastructure installed is safe and fit for purpose.
- H.2 Waterford City and County Council will not take in charge any lighting infrastructure that does not meet the minimum standards and specifications laid down in this document, national codes of practise, international standards or statutory requirements.
- H.3 A full inspection of the public lighting infrastructure may be undertaken by a representative or agent of Waterford City and County Council, the cost of which will be borne by the developer.
- Should any deficiencies be found, they must be put right at the developer's cost before the lighting will be taken in charge.
- H.4 Waterford City and County Council shall not be liable for any maintenance or energy costs incurred prior to taking public lighting infrastructure in charge.
- H.5 Lighting equipment shall not be operated prior to inspection and approved permanent connection. It must not be operated as site lighting.
- H.6 Temporary connections shall not be undertaken.
- H.7 The developer or the designer/contractor should compile the following information essential for the Council's inspectors to complete their task and submit it, prior to inspection:

Copy of written approval of original design submission and written approval of any changes.

'As constructed' geo referenced CAD drawing in soft format showing the following information:

- Street Names
- House numbers
- Individually numbered column locations. The icon scale should be such that set back can be accurately assessed
- Ducting locations
- Cable access chambers
- Individually numbered micro pillar locations
- ESB cabinet locations
- Individually numbered single line circuit diagrams
- Private areas not to be taken in charge shall be hatched and identified.



Addendum 1 Designer Checklist

To ensure that your public lighting design application meets all requirements, please complete the following check list and attach all required documentation. Approval will not be granted if documents are missing or incomplete.

No lighting infrastructure installation may commence until written approval has been received.

Project name: _____
 Project location: _____
 Developer: _____
 Developer contact Details: _____
 Planning register number: _____
 Lighting designer: _____
 Designer contact details: _____
 Lighting class selected: _____

Approval for your lighting design cannot be processed or approved without the following documentation. Please confirm it has been completed and attached with your application:

Lighting Reality® calculation in soft format
 Lighting Reality® Report in PDF format
 CAD drawing in soft format

Showing:

- The site boundary
- Private areas hatched and identified
- Landscaping features such as trees
- Individually numbered column locations
- Ducting run locations
- Cable access chambers
- Individually numbered micro pillar locations
- ESB cabinet locations
- Individually numbered single line circuit diagrams
- All other services

Technical specifications for the proposed equipment including TM 21 and LM80 report
 Written details of warranties and access to warranty procedure
 Voltage drop calculation for each circuit
 Energy calculations reflecting the designed dimming profile
 Designers risk assessment report

Sign _____

Print _____

Date _____



© COPYRIGHT RESERVED (Redmond AMS Ltd.)



Drawing title: Duct Detail	
Project title: Public Lighting Specification	
Client: Waterford City And County Council	
Project number: 19060	Date: 22/1/20
Drawing number: 19060 - 1	Revision: 0
Drawn by: Patrick Redmond	
Read in conjunction with associated lighting calculations	
Do not scale from drawing All dimensions in mm	
Document control: TD 09	Version: 1.0
Redmond Analytical Management Services Ltd.	
053 9383696 info@redmondams.ie www.redmondams.ie	
Associate Member ~ Society of Light and Lighting	
Associate Member ~ Institution of Lighting Professionals	





Addendum 3

Cable Access Chamber Detail



© COPYRIGHT RESERVED (Redmond AMS Ltd.)

Drawing title: Cable Access Chamber Detail	
Project title: Public Lighting Specification	
Client: Waterford City And County Council	
Project number: 150060	Date: 22/1/20
Drawing number: 19060 - 2	Revision: 0
Drawn by: Patrick Redmond	
Read in conjunction with associated lighting calculations	
Do not scale from drawing All dimensions in mm	
Document control: TD 09	Version: 1.0
Redmond Analytical Management Services Ltd.	
053 9383696 info@redmondams.ie www.redmondams.ie	
 REDMOND ANALYTICAL MANAGEMENT SERVICES LIGHTING ENERGY DESIGN SUPPORT	
Associate Member ~ Society of Light and Lighting	
Associate Member ~ Institution of Lighting Professionals	
	

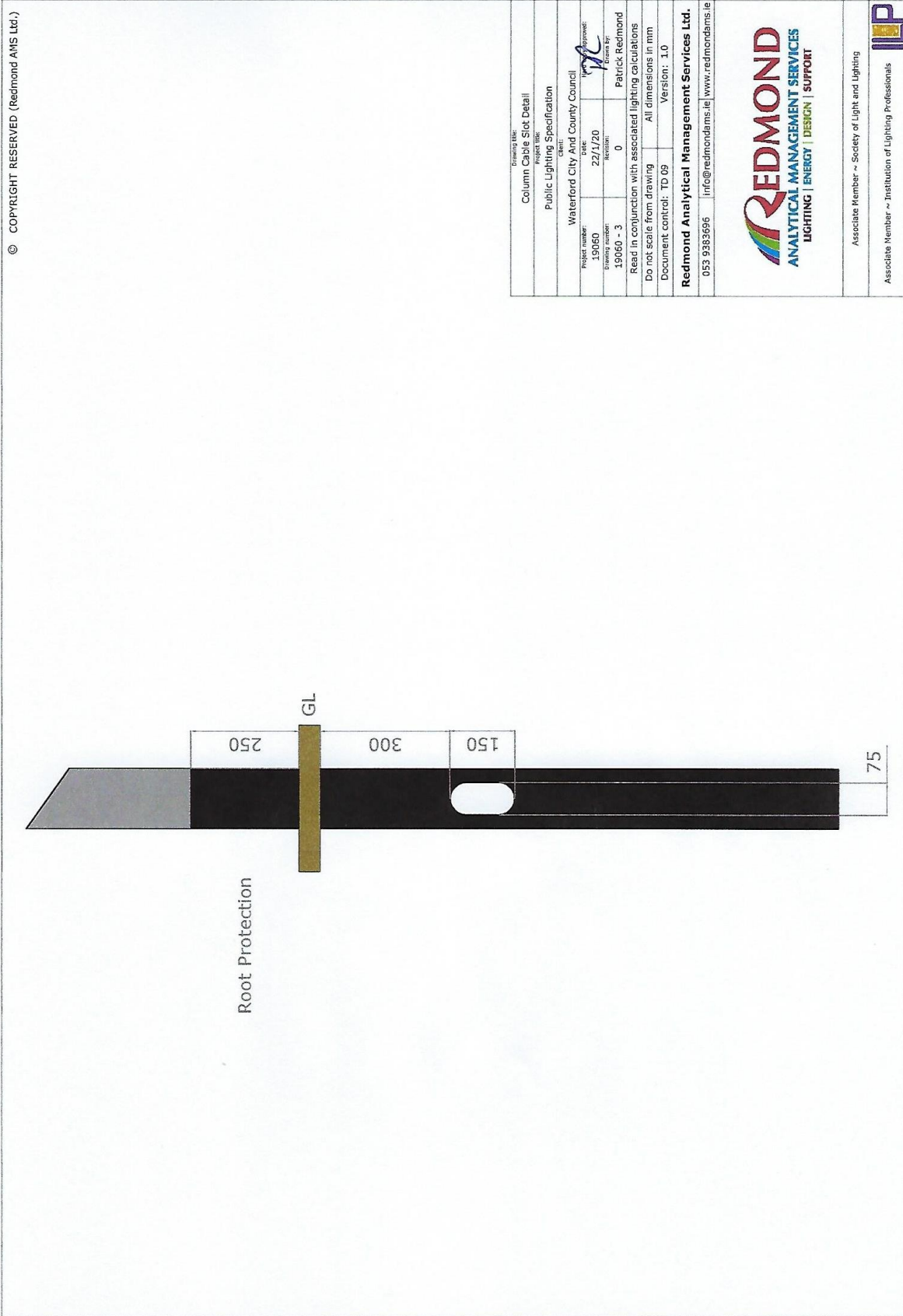

© COPYRIGHT RESERVED (Redmond AMS Ltd.)

Revision No:	Column Cable Slot Detail				
Project Name:	Public Lighting Specification				
Client:	Waterford City And County Council				
Project number:	19060	Date:	22/1/20	Drawn By:	Patrick Redmond
Drawing number:	19060 - 3	Revision:	0	Checked By:	
Read in conjunction with associated lighting calculations					
Do not scale from drawing All dimensions in mm					
Document control: TD 09 Version: 1.0					
Redmond Analytical Management Services Ltd.					
053 9383696 info@redmondams.ie www.redmondams.ie					
					
Associate Member - Society of Light and Lighting					
Associate Member - Institution of Lighting Professionals					



Addendum 5

Door Height Detail

© COPYRIGHT RESERVED (Redmond AMS Ltd.)

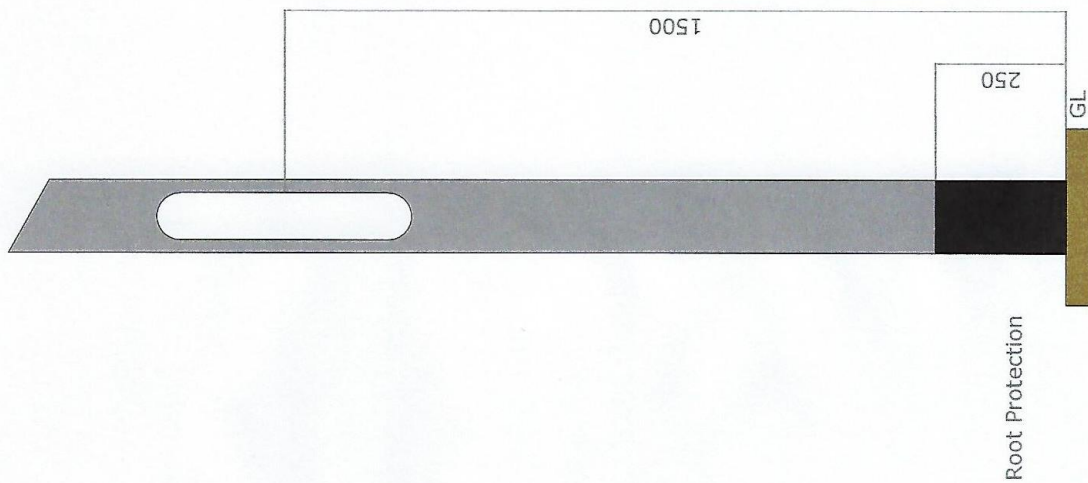

Drawing title: Column Door Detail	
Project title: Public Lighting Specification	
Client: Waterford City And County Council	
Project number: 19060	Date: 22/1/20
Drawing number: 19060 - 4	Revision: 0
Drawn by: Patrick Redmond	
Approved by: 	
Read in conjunction with associated lighting calculations	
Do not scale from drawing	
All dimensions in mm	
Document control: TD 09	Version: 1.0
Redmond Analytical Management Services Ltd.	
053 9383696 info@redmondams.ie www.redmondams.ie	



REDMOND
ANALYTICAL MANAGEMENT SERVICES
LIGHTING | ENERGY | DESIGN | SUPPORT

Associate Member ~ Society of Light and Lighting
Associate Member ~ Institution of Lighting Professionals



Addendum 6 Column Orientation Detail



© COPYRIGHT RESERVED (Redmond AMS Ltd.)

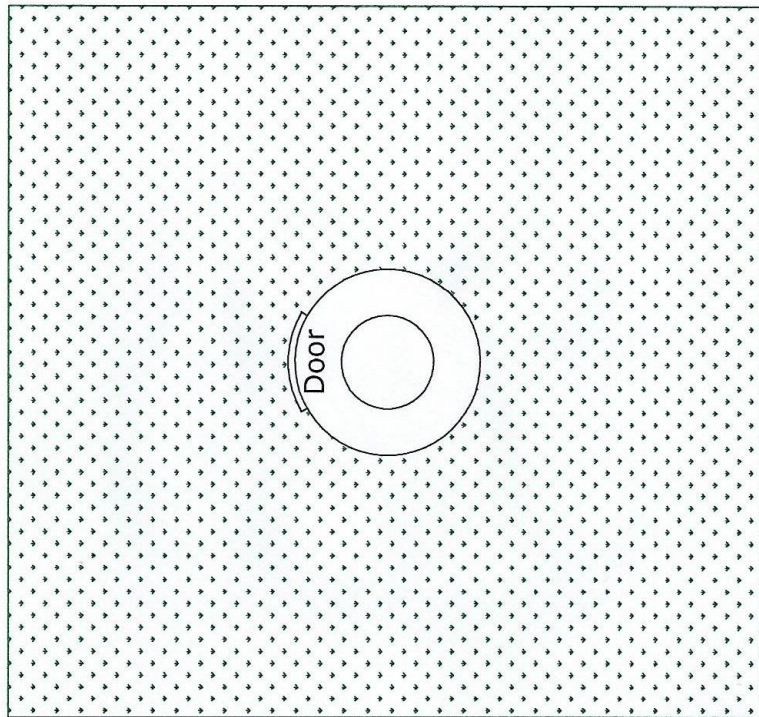

Project Name: Column Orientation Detail	
Project Title: Public Lighting Specification	
Client: Waterford City And County Council	
Project number: 19060	Date: 22/1/20
Drawing number: 19060 - 5	Revision: 0
Drawn by: Patrick Redmond	
Do not scale from drawing Read in conjunction with associated lighting calculations	
All dimensions in mm	
Document control: TD 09	Version: 1.0
Redmond Analytical Management Services Ltd.	
053 9383696 info@redmondams.ie www.redmondams.ie	
 REDMOND ANALYTICAL MANAGEMENT SERVICES LIGHTING ENERGY DESIGN SUPPORT	
Associate Member ~ Society of Light and Lighting	
Associate Member ~ Institution of Lighting Professionals	



Addendum 7 6m & 8m Column Foundation Detail

© COPYRIGHT RESERVED (Redmond AMS Ltd.)

To suit column, loading, and soil type.

250
200
600
200
50
300

Root Protection
Concrete Cap
Compacted Sand
Concrete
Duct
Column

Drawing title: 6m & 8m Column Foundation Detail	
Project title: Public Lighting Specification	
Client: Waterford City And County Council	
Project number: 19060	Date: 22/1/20
Drawing number: 19060 - 6	Hard copy approval: Drawn by: Patrick Redmond
	Version: 0
Read in conjunction with associated lighting calculations	
Do not scale from drawing All dimensions in mm	
Document control: TD 09	Version: 1.0
Redmond Analytical Management Services Ltd. 053 9383696 info@redmondams.ie www.redmondams.ie	

REDMOND
ANALYTICAL MANAGEMENT SERVICES
LIGHTING | ENERGY | DESIGN | SUPPORT

Associate Member ~ Society of Light and Lighting
Associate Member ~ Institution of Lighting Professionals

IIP

Note that these dimensions will vary due to soil types and column styles



Addendum 8 10 and all Traffic Route Column Foundation Detail

© COPYRIGHT RESERVED (Redmond AMS Ltd.)

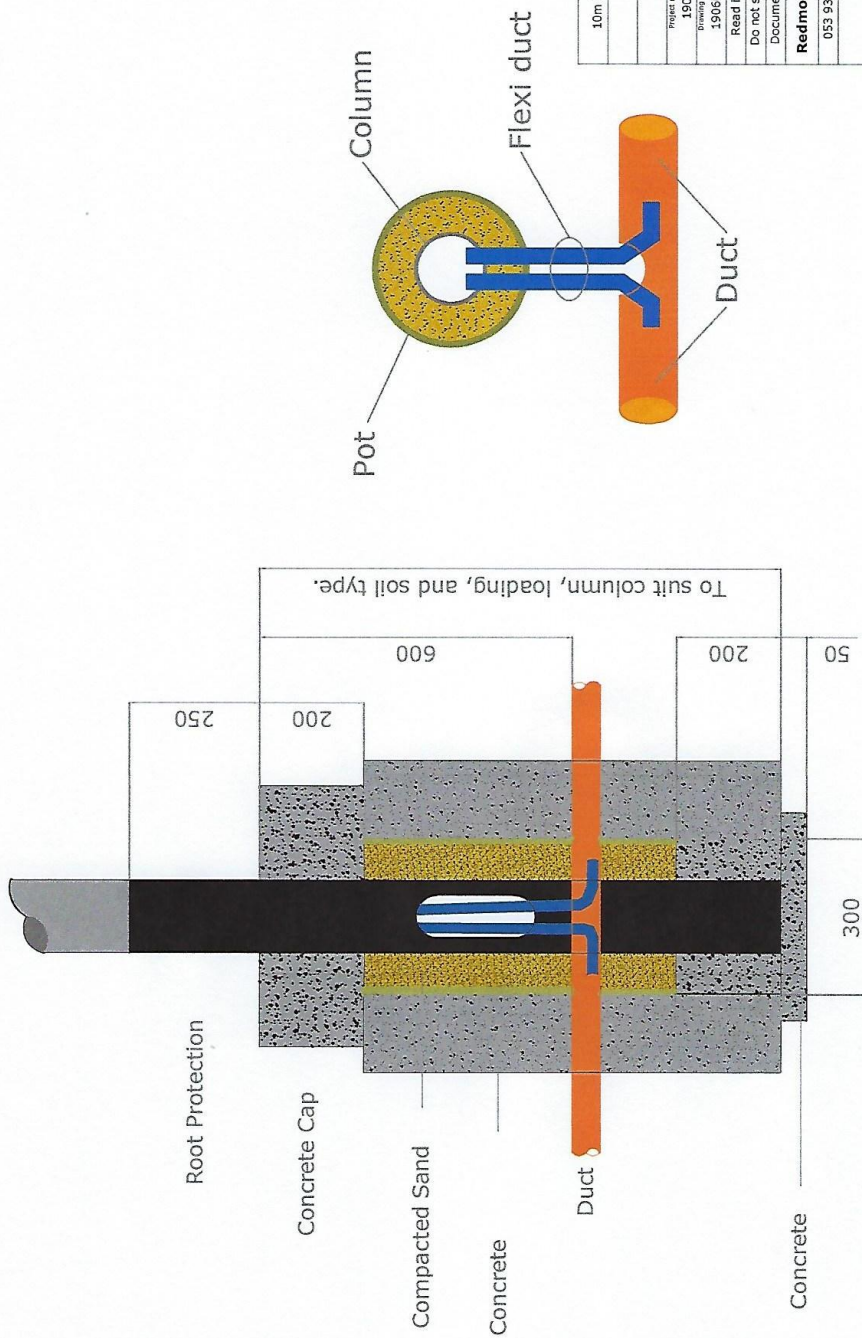

Note that these dimensions will vary due to soil types and column styles

Contract ref:		10m Plus, and Traffic Route Column Foundation Detail	
Project file:		Public Lighting Specification	
Client:		Waterford City And County Council	
Project number:	19060	Date:	22/1/20
Drawing number:	19060 - 7	Revision:	0
Drawn by:		Patrick Redmond	
Read in conjunction with associated lighting calculations			
Do not scale from drawing All dimensions in mm			
Document control:	TD 09	Version:	1.0
Redmond Analytical Management Services Ltd.			
053 9383696		info@redmondams.ie www.redmondams.ie	



Associate Member ~ Society of Light and Lighting

Associate Member ~ Institution of Lighting Professionals

