



# RENEWABLE ENERGY STRATEGY

FOR WATERFORD CITY & COUNTY

2016-2030



# TABLE OF CONTENTS

<b>Introduction</b> .....	<b>6</b>
<b>1.0 Renewable Energy Overview</b> .....	<b>7</b>
1.1 What is Renewable Energy .....	7
1.2 Why do we need Renewable Energy? .....	7
1.3 Why prepare a Renewable Energy Strategy .....	9
1.4 Strategic Aims of Renewable Energy Strategy & Vision .....	9
1.5 Public Consultation .....	10
<b>2.0 Legislative &amp; Policy Context</b> .....	<b>10</b>
2.1 International Context .....	10
2.2 European Context .....	10
2.3 National Context .....	11
2.4 Regional Context .....	12
2.5 County Context .....	13
<b>3.0 Energy Profile of Waterford City and County</b> .....	<b>13</b>
3.1 Covenant of Mayors .....	13
3.2 Waterford Energy Balance .....	14
3.3 Energy Demand by Sector .....	15
3.4 Energy Demand by Fuel Type .....	16
<b>4.0 Renewable Energy Technologies</b> .....	<b>20</b>
4.1 Onshore Wind .....	20
4.2 Onshore Wind Energy Development in Waterford .....	20
4.3 Current Waterford Onshore Wind Energy Policy .....	22
4.4 Advantages/Disadvantages of Onshore Wind Energy for Waterford	23
<b>5.0 Solar Energy</b> .....	<b>24</b>
5.1 Solar Farm Development in Waterfor .....	24
5.2 Solar Potential in Waterford .....	24
5.3 Types of Solar Energy .....	26
5.4 Advantages/Disadvantages of Solar Energy for Waterford .....	27

<b>6.0</b>	<b>Hydroelectric Power .....</b>	<b>27</b>
6.1	Hydropower in Waterford .....	28
6.2	Types of Hydroelectric Schemes .....	28
6.3	Hydropower Potential in Waterford .....	29
6.4	Advantages/Disadvantages of Hydropower for Waterford .....	29
<b>7.0</b>	<b>Bioenergy .....</b>	<b>31</b>
7.1	Bioenergy Development in Waterford .....	32
7.2	Bioenergy Potential in Waterford .....	33
7.3	District Heating Schemes .....	38
7.4	Advantages/Disadvantages of Bioenergy for Waterford .....	38
<b>8.0</b>	<b>Marine Renewable Energy .....</b>	<b>39</b>
8.1	Introduction and Background .....	41
8.2	Offshore Wind .....	43
8.3	Tidal Energy .....	53
8.4	Wave Energy .....	44
8.5	Advantages/Disadvantages of Marine Renewable Energy for Waterford .....	45
<b>9.0</b>	<b>Micro Renewable Energy Generation .....</b>	<b>45</b>
9.1	Micro Renewable Development in Waterford .....	46
9.2	Micro Renewable Potential in Waterford .....	58
9.3	Advantages/Disadvantages of Micro-Generation for Waterford .....	47
<b>10.0</b>	<b>Miscellaneous Renewables .....</b>	<b>47</b>
10.1	Geothermal Energy .....	47
10.2	Combined Heat and Power - Natural Gas .....	48
<b>11.0</b>	<b>Renewable Transport Technologies .....</b>	<b>49</b>
11.1	Transport .....	49
11.2	Electric Vehicles .....	49
11.3	Biofuels .....	50
<b>12.0</b>	<b>Supporting Infrastructure .....</b>	<b>50</b>
12.1	Introduction .....	50
12.2	Grid Connection .....	50
12.3	Electricity Supply Network .....	51
12.4	Gas Network .....	52
12.5	Smart Grid .....	52



12.6	Road Network .....	53
12.7	Ports/Harbours/Piers .....	53
12.8	Energy Storage .....	54
12.9	Renewable Energy Support Schemes .....	54
<b>13.0</b>	<b>Strategic Planning Considerations .....</b>	<b>55</b>
13.1	Renewable Energy and Protection of the Environment .....	55
13.2	Renewable Energy and the Landscape .....	55
13.3	Renewable Energy and consideration of External Factors .....	55
13.4	Renewable Energy and Spatial Planning .....	57
13.5	Renewable Energy and Community .....	58
13.6	Renewable Energy Strategy and Monitoring .....	59
<b>Appendices</b>		
<b>Appendix 1</b>	<b>Glossary of Terms .....</b>	<b>60</b>
<b>Appendix 2</b>	<b>Waterford Wind Energy Strategy .....</b>	<b>62</b>
<b>Appendix 3</b>	<b>Grid Applications .....</b>	<b>63</b>
<b>Appendix 4</b>	<b>SEA Screening Report .....</b>	<b>65</b>
<b>Appendix 5</b>	<b>AA Screening Report .....</b>	<b>73</b>
<b>Appendix 6</b>	<b>Maps .....</b>	<b>80</b>

## INTRODUCTION

Energy is fundamental to all our lives. The development of renewable energy has become a central focus of Ireland's energy policy and it is anticipated that renewable energy will play a major role in addressing our energy challenges over the coming decades.

Renewable energy reduces dependence on fossil fuels, improves security of supply and reduces greenhouse gas emissions. Renewable energies thus provide environmental benefits whilst also being complimentary to economic growth.

There is now a scientific consensus that climate change is happening, that it is directly related to man-made greenhouse gas emissions, and that it is imperative that we act now to avoid devastating impacts on our planet.

There is also an economic consensus that the costs of doing nothing will greatly outweigh the costs of action, and that progressive renewable energy policies, based on innovation and investment in low-carbon technology, are consistent with economic growth.

To date, onshore wind has largely been the main renewable energy source deployed in Ireland. However, no single renewable energy technology will assist Ireland's transition to renewable energy but rather a diverse range of technologies will be required.

Another important component of Ireland's transition to renewable energy will involve the role of citizens and communities both through active participation in renewable energy generation and energy efficiency and through improved community engagement in policy formulation and implementation.

This Renewable Energy Strategy has been prepared for Waterford City and County in the context of EU and national renewable energy targets. Waterford has varied renewable energy resources with objectives to support the development of renewable energy contained in the Waterford County Development Plan 2011-2017 & Waterford City Development Plan 2013-2018 and Dungarvan Town Development Plan 2012-2018. The purpose of this Renewable Energy Strategy is to provide a strategic document which will underpin these Plans and inform their future review.

The Renewable Energy Strategy examines the renewable energy potential for the city and county and considers the strategic planning factors contributing towards the deployment of such renewable energy. It also highlights the importance of integrating renewable energy and landuse planning. To this end, the Strategy recognises that there is a need to strengthen links between renewable energy and landuse planning through County Development Plans, Strategic Development Zones and other local plans.

The Strategy forms part of the Waterford City Development Plan 2012-2018, Waterford County Development Plan 2011-2017 and Dungarvan Town Plan 2012-2018, and will be adopted by way of variation to these plans, respectively. It is underpinned by a Strategic Environmental Screening Assessment and a Habitats Directive Screening Assessment. These assessments are attached as appendices to this document.

## 1.0 RENEWABLE ENERGY OVERVIEW

### 1.1 What is Renewable Energy?

Renewable energy is energy derived from natural resources that are continuously replenished through the cycles of nature. They can be harnessed without damaging the environment, unlike using fossil fuels which release carbon dioxide (a greenhouse gas) and other harmful pollutants into the atmosphere.

Some renewable technology is well developed (e.g. wind) and other areas need more research and development (e.g. wave). Therefore, the technical and commercial viability of each source varies considerably. Renewable sources include:

<b>Solar Biomass</b>	
Passive solar design	Energy crops
Active solar heating	Forestry
Photovoltaics	Biogas
<b>Hydro</b>	Anaerobic digestion
Hydroelectric (large scale)	Municipal waste
Hydroelectric (small scale)	Agricultural/forestry waste
Tidal	<b>Geothermal</b>
Wave	
<b>Wind</b>	<b>Heat pumps</b>
Onshore	Water source
Offshore	Heat source

### 1.2 Why do we need Renewable Energy?

Ireland is heavily dependant on imported fossil fuels such as oil, gas and coal. Imported oil remains the single largest source of energy, and is a major source of green house gas emissions. Currently, we import 85% of the fuels we need for energy<sup>1</sup> which is well above the EU average. The development of an indigenous renewable industry is important for the following reasons:

- Security of supply – necessary to the functioning of society and the economy;
- Sustainability – it reduces reliance on imported fossil fuel and can be harvested without damaging the environment;
- Reduced CO<sub>2</sub> emissions – cleaner, less polluting energy sources ;
- Competitiveness – less exposure to volatile global energy prices;

<sup>1</sup> [SEAI Statistics Portal 1990-2014](#), Sustainable Energy Authority of Ireland

- Investment and employment opportunities. Economic development in rural and under-developed areas;
- Compliance with EU & National binding renewable energy targets.

Ireland has a legally binding target for renewable energy as well as a national target for energy efficiency which must be met by 2020. The avenue for achieving these targets is set out in the National Renewable Energy Action Plan 2010 and the National Energy Efficiency Action Plan 2014. The NREAP 2010 sets out how Ireland intends to achieve the target of 16% renewable energy share of national energy consumption by 2020 in the following sectors:

Sector	Target for 2020
Electricity	40%
Heating & Cooling	12%
Transport	10%
Overall Target	16%

Source: National Renewable Energy Action Plan, 2010

The EU 2030 Framework for Climate and Energy has defined further EU wide targets including at least 27% renewable energy share. This target is binding at EU level and will have to be incorporated into energy policy in Ireland.

To achieve these European and national targets, the delivery of renewable energy infrastructure and the production of renewable energy infrastructure will have to undergo a substantial transformation at the national level and also at the county level.

Failure to meet these targets will result in monetary fines for Ireland post 2020.

Renewable Energy in Ireland - at a glance
Renewable energy contributed 7.8% of gross final energy consumption, almost halfway towards Ireland's legally binding 2020 target.
Renewable electricity accounted for 58% of renewable energy, renewable heat 30% and renewable transport fuels 12%.
The vast majority of renewable energy came from wind (47%) and bioenergy (42%) with the remainder from hydro, geothermal and solar.
(Source: Renewable Energy in Ireland 2013 SEAI 2015)

### **1.3 Why prepare a Renewable Energy Strategy?**

As the technology for generating renewable energy continues to improve, so too does the need for clear planning policy and objectives that are sufficiently robust, and to ensure that a consistent approach to the planning and development of renewable energy is employed at local authority level.

This Renewable Energy Strategy has been developed as a planning framework to support and underpin the Core Strategy and policies and objectives of the Waterford City Development Plan 2012-2018, Waterford County Development Plan 2011-2017 and Dungarvan Town Plan 2012-2018. This Renewable Energy Strategy aims to ensure that Waterford is at the forefront of renewable energy production whilst equally promoting energy efficiency and conservation in all sectors of the economy.

Waterford has the potential to maximise energy generation by renewable means, which will contribute to a reduction of energy imports, address security of supply issues, provide a secure, indigenous source of energy whilst also keeping wealth within the local economy. Its coastal location coupled with a strong wind resource, good solar irradiation and a significant grid network present opportunities to maximise energy generation by renewable means. County Waterford is also ideally placed to maximise the potential of bio-energy. There is a strong forestry resource combined with heat demand centres at inter alia Dungarvan and Lismore, which could provide a viable opportunity for combined heat and power technology in particular.

#### **Vision of Renewable Energy Strategy**

To provide a strategy to maximise Waterford's renewable energy potential and its transition to becoming a more energy secure, low carbon county in line with national energy targets whilst balancing the need to protect the environmental, social and heritage assets of the city and county.

### **1.4 Strategic Aims of the Renewable Energy Strategy**

- To ensure that between now and 2030, there is a steady, progressive and measurable increase in the amount of renewable energy used in the electricity, heat and transport sectors in Waterford, commensurate with the achievement of the national target.
- To identify opportunities for various renewable energy technologies and resources appropriate to Waterford.
- To maximise the opportunities for renewable energy development whilst safeguarding the environment and other amenities, subject to Strategic Environmental Assessment and Habitats Directive Assessment requirements.

## 1.5 Public Consultation

Consultation with stakeholders formed a key part of the preparation of this Renewable Energy Strategy. Pre-draft consultation took place in March 2016 and statutory public consultation was undertaken in June 2016, with the general public and key stakeholders associated with energy. Written submissions were invited and all submissions were summarised and considered during the preparation of the Renewable Energy Strategy.

A Renewable Energy sub-committee comprising members of the Planning SPC was established, ensuring elected members and community groups were fully informed and involved in the content and policy formulation of this Renewable Energy Strategy.

## 2.0 LEGISLATIVE & POLICY CONTEXT

The context for this Renewable Energy Strategy is set in a hierarchy of international and national legislation and policy, which provides the statutory basis for the preparation of plans and strategies for the protection of the environment. The following list is not exhaustive but highlights the main legislation and publications which have informed this RES.

### 2.1 International Context

#### **Kyoto Protocol**

The Kyoto Protocol 1997 is an international climate change agreement which sets legally binding targets for industrialised countries including Ireland to reduce greenhouse gas emissions. Increasing the use of renewable energy is therefore a key strategy for reducing greenhouse gas emissions and meeting Ireland's Kyoto commitments.

#### **Paris Climate Change Agreement (COP21)**

The Paris Agreement is the first ever global, legally binding climate change accord which seeks to tackle climate change by limiting global warming to well below 2 degrees celcius.

### 2.2 European Context

#### **Directive 2009/28/EC - Promotion of the Use of Energy from Renewable Sources**

Renewable energy policy in Ireland is guided by European Union requirements. This Directive establishes that 20% of energy consumption in the EU is to come from renewable sources by 2020. The Directive's specific target for Ireland is that 16% of Ireland's energy consumption will be from renewable sources by 2020 across the transport, heat and electricity sectors. The Directive also required that member states prepare a National Renewable Energy Plan (NREAP) by June 2010.

EU 20-20-20 Agreement aims to ensure that the EU meets ambitious climate and energy targets up to 2020. The 20-20-20 target sets three key objectives:

- 20% greenhouse gas reduction from 1990 levels;
- 20% of all energy to come from renewable energy sources;
- 20% improvement in energy efficiency.

The EU 2030 Framework for Climate and Energy marks a further development of EU renewable energy policy. The Framework was adopted by EU leaders in October 2014 and sets a 40% green house gas (GHG) reduction on 1990 GHG levels, and an EU-wide target of 27% for renewable energy and energy savings by 2030.

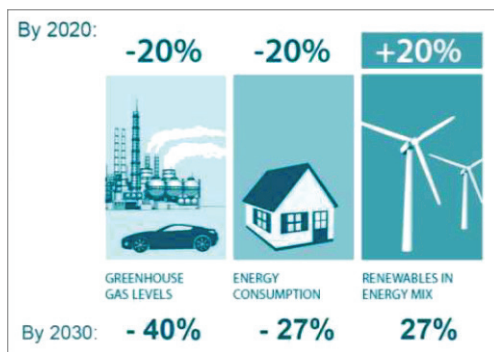

FIGURE 3: EU 2020 AND 2030 TARGETS FOR GHG, ENERGY CONSUMPTION AND RENEWABLE ENERGY (SEAI)

## 2.3 National Context

### White Paper - Ireland's Transition to a Low Carbon Energy Future 2015-2030

The White Paper sets out Ireland's overall energy policy at a strategic level up to 2030. In the White Paper, strong emphasis is placed on the further development of the renewable energy sector.

### National Renewable Energy Action Plan 2010-2020 DCENR 2010

The National Renewable Energy Action Plan (NREAP) sets out the Government's strategic approach and concrete measures to deliver on Ireland's national target of 16% renewable energy under Directive 2009/28/EC. This action plan will be subject to several 'progress reports', the latest of which was submitted in 2014.



### **National Energy Efficiency Action Plan 2013-2020**

The NEEAP aims to secure a 20% increase in energy efficiency by 2020. From a renewable energy perspective, energy efficiency is a key issue to be addressed in maximising the impact of renewable energy. Targets include:

- Reducing public sector energy consumption by 33%;
- Provison of grants for homeowners to increase energy efficiency.

The implementation of measures under the NREAP and the NEEAP are equally important in meeting Ireland's energy target obligations.

### **The Climate Action and Low Carbon Development Act 2015**

This Act, Ireland's first-ever dedicated climate change legislation, provides for the making of:

- Five-yearly National Mitigation Plans to specify the policy measures required to reduce greenhouse gas emissions;
- A National Adaptation Framework to specify measures required in different sectors and by local authorities to mitigate against the negative effects of climate change.

### **Offshore Renewable Energy Development Plan 2014**

The prospects for wave and tidal energy are good in the longer term, when the technology has been sufficiently developed. The OREDP envisages that energy from wave and tidal resources is unlikely to be available in significant quantity until after 2030, due to the current state of technological development.

### **Planning and Development Act (as amended)**

The Planning and Development Act (as amended) in conjunction with the Planning and Development Regulations (as amended) include planning exemptions for specified micro-renewable energy technologies for domestic, industrial, commercial and agriculture developments. Also, it is a mandatory requirement to consider the effects of climate change through policies and strategies within a plan or incorporated as part of a development plan.

## **2.4 Regional Context**

### **South East Regional Planning Guidelines 2010-2022**

The South East Regional Planning Guidelines recognises that the region has substantial renewable energy resource potential. Section 6.3.3 provides for the development of a Climate Change Action Plan in partnership with the local authorities, local energy agencies and other stakeholders.

### **South-East Regional Authority Bio-Energy Implementation Plan 2013-2020**

The Bio-Energy Implementation Plan for the South-East identifies the bio-energy resources for the region and opportunities for their development. It is a target of the Plan that 17% of total energy supply will come from biomass by 2020. The Plan supports the investigation of the potential of using wheat, barley and sugar beet for biofuel.

## **2.5 County Context**

### **Waterford County Development Plan 2011-2017 & Waterford City Development Plan 2012-2018**

The Waterford CDP contains a number of objectives regarding renewable energy and micro-renewables. The City Plan recognises that Waterford can be Ireland's Lead City in Sustainable Energy Technologies. Both plans acknowledge the role bio-energy can play in renewable energy production.

A Climate Change Strategy, which seeks to progress sustainable energy projects, was developed by the former City and County Councils in 2011 and 2007 respectively.

### **Local Economic and Community Development Plan 2015**

This Plan has identified growth potential in the Green Enterprise sector which it is envisaged will bring economic diversification opportunity to Waterford and which could link in with Waterford Institute of Technology's Innovation Research Centre. It is a strategic objective of the LECP to:

- To facilitate appropriate renewable energy infrastructure and promote the use of renewable energy among business.

## **3.0 ENERGY PROFILE OF WATERFORD CITY AND COUNTY**

The Council recognises its role in fulfilling the renewable energy commitments made at national level. The Council has identified its strategic aims for renewable energy in the Waterford County Development Plan, Waterford City Development Plan and Dungarvan Town Development Plan. The Waterford Energy Bureau (WEB) is also a key player in the roll out and development of renewable energy in the city and county.

### **3.1 Waterford Energy Balance**

The Waterford Energy Bureau has developed an Energy Balance for Waterford, which assesses current and future energy demand up to 2020 and 2030. Energy consumption has been broken up into three energy categories comprising electrical, heat and transport energy. Energy consumption is also represented within five sectors including residential, industry, services, agriculture and transport.

The following tables provide an overview of the County's energy needs and set out projections<sup>3</sup> up to 2030<sup>4</sup>. These projections are predicated on the continued development and investment into energy efficiency and renewable energy sources. Total energy usage in County Waterford is predicted as linear, with only the proportions of the energy demand from renewable or non-renewable sources varying. Overall the expectation is for a reduction in demand for non-renewable energy sources, such as coal, oil and gas, and an increased demand for electricity from all sectors, leading to cleaner, more sustainable energy usage across the county. Since 2008, energy demand in Waterford has reduced annually as a consequence of the economic downturn. Modest economic growth forecasts point towards an increase in energy consumption, nearing 2010 levels by c. 20235 - See Table 3.1.

## 3.2 Energy Demand by Sector

Currently the largest energy demand in Waterford is from the Transport sector, comprising of public transport, private, & commercial vehicles; it is in this sector where investment in clean and efficient renewable energy is projected to have the greatest impact. However, it must be acknowledged that the conversion of the transport sector to more efficient and renewable fuels will be difficult to achieve both at national and county level.

Although overall energy usage in Waterford is increasing, a decrease in energy usage from the Residential and Services sectors is expected, owing to general improvements in the energy efficiency of technology, and significant reductions in the energy usage of new and upgraded buildings.

### Waterford's energy demand by sector, 2010-2030

Sector	Energy (GWh)				
	2010	2016	2020	2025	2030
Residential	981	831	760	700	696
Industry	604	661	671	704	797
Services	501	389	374	366	388
Agriculture	71	86	88	94	109
Transport	1,132	1,102	1,178	1,318	1,592
<b>Total</b>	<b>3,289</b>	<b>3,068</b>	<b>3,070</b>	<b>3,183</b>	<b>3,582</b>

Table 3.1 Waterford Energy Consumption by sector [Source: Waterford Energy Bureau]

<sup>3</sup> SEAI *Energy Forecast for Ireland to 2020 (2011)*.

<sup>4</sup> Figures have assumed that the percentage changes in each sector will remain constant from 2020 to 2030.

<sup>5</sup> *ibid*

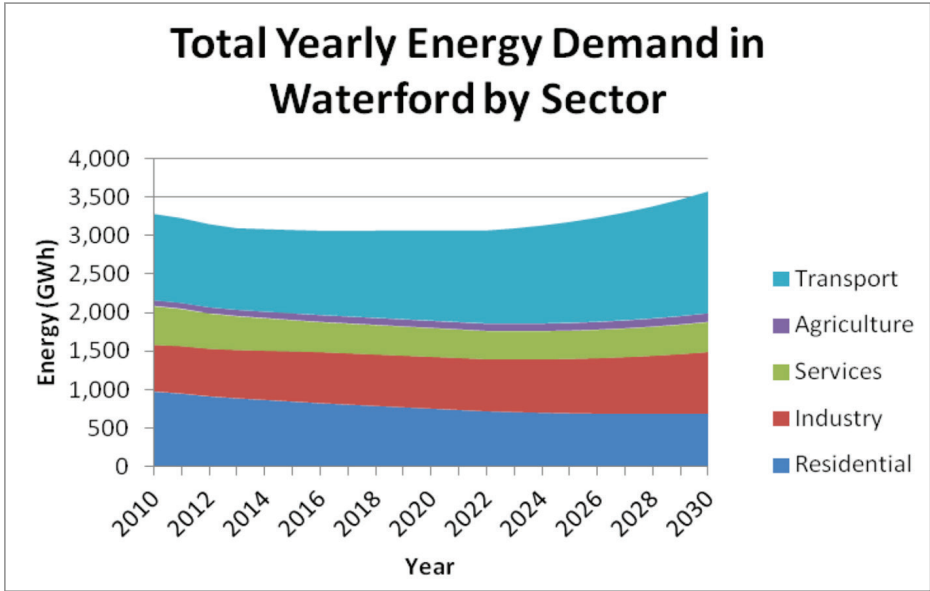

Figure 3.1 Waterford Energy Demand by sector [Source: Waterford Energy Bureau]

### 3.3 Energy Demand by Fuel type

Having considered future energy demands for Waterford, it is also necessary to assess the types of fuel that are used to meet these energy demands and to analyse future needs. Waterford is almost entirely dependent on imported oil for heat and transport. In this regard, it is very evident that oil represented the largest quantity of energy usage by fuel type in 2016, at just under 60% of Waterford’s energy demand.

Fuel	Energy (GWh)				
	2010	2016	2020	2025	2030
Coal	104	55	35	21	12
Oil	1,894	1,658	1,594	1,398	1,386
Gas	474	451	389	330	273
Peat	76	67	57	31	16
Non-Renewable Waste	3	3	3	3	3
Renewable Heat Energy	93	179	250	280	343
Electricity	647	655	743	1,120	1,550
<b>Total</b>	<b>3,289</b>	<b>3,068</b>	<b>3,070</b>	<b>3,183</b>	<b>3,582</b>

Table 3.2 Waterford’s energy demand by fuel type, 2010-2030 [Source: Waterford Energy Bureau]

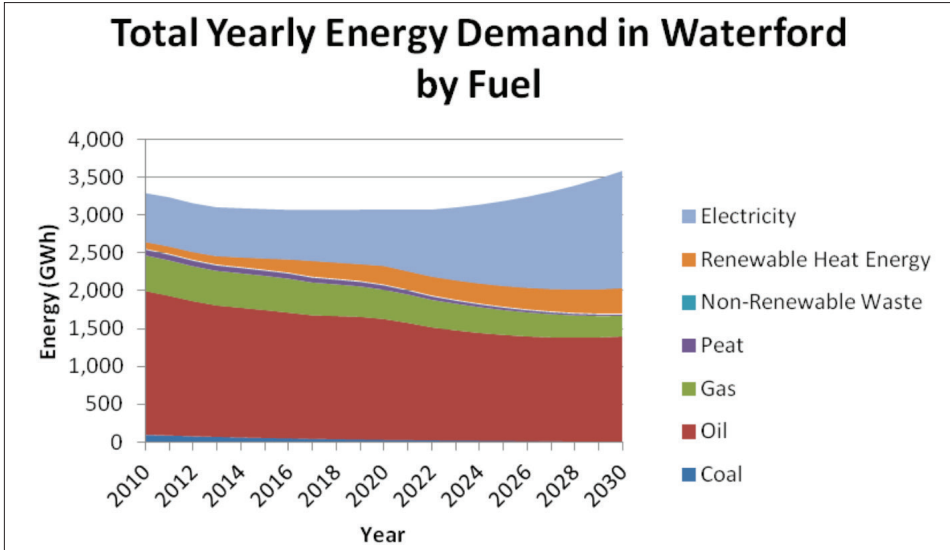

Figure 3.2 Waterford’s energy demand by fuel type, 2010-2030. [Source: Waterford Energy Bureau]

Overall, as per Table 3.2, the energy expectation for Waterford up to 2030 is as follows:

- A reduction in demand for non-renewable energy sources, such as coal, oil and gas, and an increased demand for electricity from all sectors, leading to cleaner, more sustainable energy usage across the county.
- A significant increase in the demand for electricity is predicted resulting in a decrease in demand for fossil fuels. A major factor in this will be the Transport sector, as electric cars are developed and become more widespread, the oil usage contributed by the sector is projected to decrease.
- A significant reduction in the use of coal and peat for home heating is anticipated due to advances in home heating technology, improvements in home insulation and new laws restricting the burning of fossil fuels for home heating due to environmental and climate change obligations.
- The use of natural gas is predicted to remain steady for Waterford, Tramore and Kilmeaden with Corrib Gas field providing security of supply up to 2030.

### 3.4 Renewable Energy Production in Waterford

Waterford currently has renewable energy production both at macro and micro level. Wind energy constitutes the dominant renewable energy form in the county, in-keeping with national trends. However, there is potentially a considerable renewable energy resource within Waterford that has yet to be exploited.

The viability of the different RE technologies varies. Many of the innovative renewable energy technologies under development are expected to be commercially viable post 2020 (e.g. Solar with others presenting longer term potential (e.g. Wave). Each renewable energy technology has positive and negative characteristics with no quick fix technology that will exclusively meet Waterford's energy needs into the future. A sustained, supported renewable energy strategy will help Waterford / Ireland deliver on its renewable energy targets, reduce fossil fuel imports and related emissions and increase economic and employment opportunity.

Table 3.3, compiled by the Waterford Energy Bureau, sets out the renewable energy generation in Waterford in 2016 and makes projections for renewable energy generation in the city and county up to 2030. Table 3.3 illustrates a varied portfolio of renewable energy resources encompassing a broad range of technologies. The projections are based on current government energy policy as per the White Paper 2015 and CSO population projections. Given the research being undertaken in respect of off-shore wind and the increased emphasis on solar and ocean energy, this Strategy recognises that offshore, solar and ocean renewable technology could play a greater role in addressing Waterford's energy needs up to 2030.

The following sections of this RES provide more detail on the respective renewable technologies which offer potential in Waterford.

### Renewable Energy Generated in Waterford in 2016 and projected to 2030

Energy Source	2016 Renewable Electricity Generation (MW)	% of Total Electricity (2016)	2030 Projected Renewable Electricity Generation (MW)	% of Total Electricity (2030)
<b>Electrical</b>				
On Shore Wind	62.9	21.68%	131.7	17.01%
Off Shore Wind	0.0	0.00%	33.0	5.94%
Solar PV	0.0	0.00%	84.1	2.89%
Hydroelectricity	1.0	0.39%	3.1	0.77%
Biomass CHP	0.0	0.00%	5.0	2.06%
Gas Fired CHP	0.4	0.36%	2.6	0.87%
Biogas CHP	0.0	0.00%	2.2	1.12%
Ocean	0.0	0.00%	10.0	0.96%
Micro	0.2	0.03%	56.9	3.00%
Total	64.5	22.46%	328.6	34.64%
Energy Source	2016 Renewable Heat Energy Generation (MW)	% of Total Heat Demand (2016)	2030 Projected Renewable Heat Energy Generation (MW)	% of Total Heat Demand (2030)
<b>Thermal (Heat)</b>				
Commercial Biomass Boilers	4.3	0.59%	12.3	3.39%
Domestic Stoves, Gassification and Woodchip boilers	40.1	5.29%	23.3	3.35%
Commercial Heat Pumps	0.1	0.02%	12.6	1.83%
Energy Crop Boilers	0.8	0.17%	5.0	1.75%
Cereals, Straw	0.5	0.07%	5.5	1.01%
Biomass CHP	0.0	0.00%	10.0	4.66%
Gas Fired CHP	0.5	0.18%	4.6	1.68%
Biogas CHP	0.0	0.00%	4.0	1.32%
Domestic Micro Thermal, including heat pumps, solar water heating, micro CHP	6.4	0.98%	124.8	19.06%
Commercial Solar Water Heating	0.0	0.01%	0.3	0.04%
Total	52.6	7.30%	202.3	38.09%
<b>Renewable Energy Use in Transport in Waterford, 2016 and 2030 Projection</b>				
Sector	% of 2016's Transport Demand		% of 2030's Projected Transport Demand	
Transport	6.36%		30.06%	
Year	% of Total Energy Demand			
<b>2016</b>	<b>10.69%</b>			
<b>2030 Projections</b>	<b>32.74%</b>			
Note: These projections indicate that the EU 2030 target requiring 27% of our Total Energy Demand to be met by renewable sources will be surpassed.				
Note: These targets have been derived from national energy targets and CSO population figures which have been extrapolated for Waterford City & County up to 2030. They are indicative only and are not intended to limit the potential for renewable energy development in Waterford.				

Table 3.3 Renewable Energy Resource Projections for Waterford up to 2030 [Source: Waterford Energy Bureau]





## 4.0 RENEWABLE ENERGY TECHNOLOGIES



### 4.1 Onshore Wind

To date, onshore wind energy has been the most significant source of renewable energy both at national and county level. Ireland has one of the most favourable climates for harnessing wind energy in Europe and this technology is the largest contributor to renewable electricity generation in the country<sup>6</sup>. However, if Ireland is to meet its national energy targets and avoid significant fines, the SEAI estimate that 250MW of wind is required to be deployed every year until 2020<sup>7</sup>. The average deployment of wind in the last few years has been 177MW per annum.

### 4.2 Onshore Wind Energy Development in Waterford

At the end of 2015, there were four operational wind farms in Waterford with a combined generation capacity of 63MW. Table 4.1 below illustrates the permitted and operational wind farms in the County.

---

6 DCENR (2016) Draft Renewable Electricity Policy & Development Framework – Draft Strategic Environmental Screening Assessment Report

7 SEAI (2016) Ireland's Energy Targets Progress, Ambition & Impacts

Wind Energy Projects in Waterford				
Wind Farm	Details	Grid Access Process (Gate)	Status	(MW)
Woodhouse	8 wind turbines of 112m tip heights	3	Operational	23.28
Ballycurreen	2 wind turbines of 120m tip height	3	Operational	4.99
Barranfaddock	11 wind turbines with 120m tip height	3	Operational	32.4
Beallough 1	2 wind turbines of 87m tip height	2	Operational	1.7
Flahavan, Kilgrange, Kilmacthomas	1 wind turbine of 82.5m tip height	Auto Producer	Operational	0.5
Aglish	To erect 12 wind turbines, tip height of approx. 126.5m and hub height 80m	3	Permission refused by WCCC. Currently on appeal.	34.00
Beallough 2	A third turbine to be added to the existing wind farm	4	Not built to date. planning permission granted.	0.85
Robertstown	5 Wind Turbines with 107m tip heights	TBC	Not built to date. Planning permission expires March 2021.	14.50
Walsh & Connors Ltd, Ballygarty, Kilmacthomas	1 wind turbine of 92.5m tip height	TBC	Not built. Planning permission expires Nov. 2017	0.5
Ian Tierney, Ballinamult	1 wind turbine with 45m tip height	TBC	Not built to date. Planning permission expires Nov. 2017	0.15
Glaxo Smith Kline Dungarvan Ltd	1 wind turbine of 130.5m tip height	TBC	Not built to date. Planning permission expires	2.3
Total				115.17
Total - In operation			62.9MW	
Total permitted - Not constructed to date.			18.27MW	
Total - On appeal			34MW	

Table 4.1 Wind Energy in Waterford

In operation.  Not constructed to date.  On appeal to An Bord Pleanala.

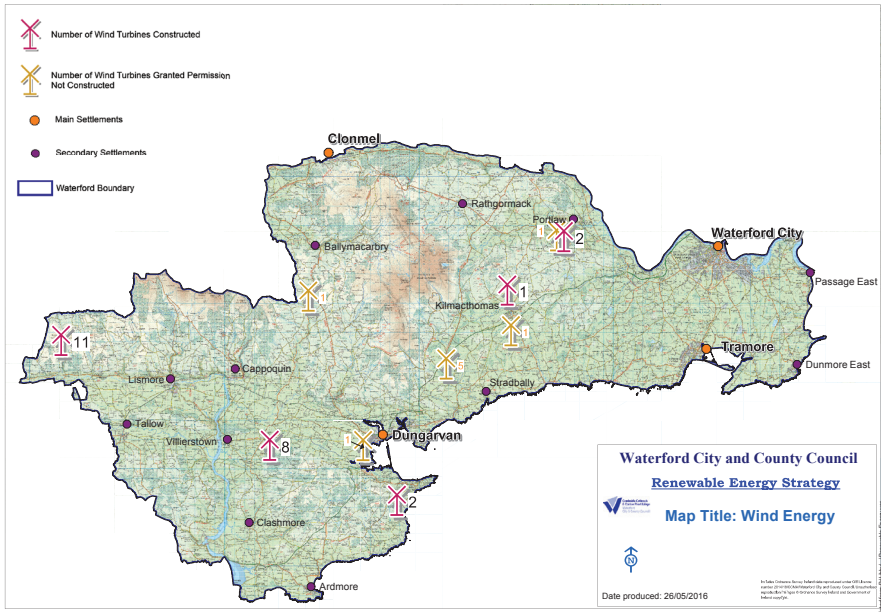

Figure 4.1 Wind Energy Development in Waterford

### 4.3 Current Waterford Onshore Wind Energy Policy 2011-2017

A Wind Energy Policy forms part of Waterford County Development Plan 2011-2017 and forms the basis for a plan led approach to wind energy development in Waterford. Please refer to Appendix 2 for details. The Wind Energy Strategy will be reviewed as part of the Waterford City & County Development Plan (post 2017).

The impact of onshore wind energy developments will vary depending on the location of the individual site together with the number of turbines, layout, size, design and colour.

Figure 4.1 below illustrates the onshore wind speeds for Ireland. Offshore wind is examined as part of Marine Renewable Energy in Section 8 of this Renewable Energy Strategy.

## 4.4 Advantages/Disadvantages of Onshore Wind Energy for Waterford

Advantages	Disadvantages
Good wind speeds	Height and mass issues
Good Grid connection	Landscape and visual impact
Advanced technology - Battery storage for excess electricity now available	Noise/shadow flicker
Efficient land cover compared to Solar	Cumulative effect of wind turbines on landscape.

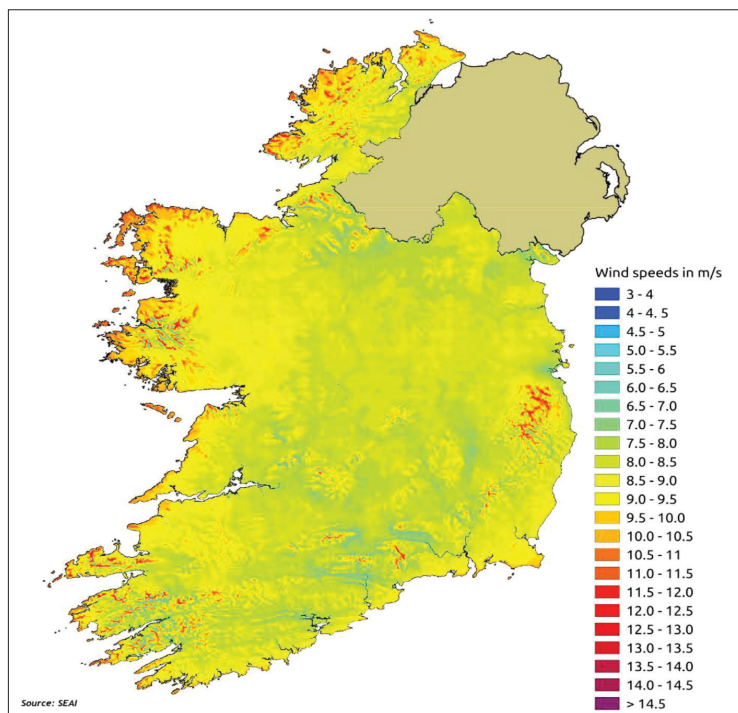

Figure 4.2 Onshore 100m wind speed [Source: SEAI]

## 5.0 SOLAR ENERGY



Solar energy is relatively well developed in Europe although it has yet to be established to any great extent in Ireland. However, as the cost of solar panels decreases and the efficiency of the technology improves, it is predicted that the development of solar energy will increase. A recent German report<sup>8</sup> has predicted that solar power will soon be the cheapest form of electricity generation for many parts of Europe.

### 5.1 Solar Farm Development in Waterford

Planning permission has recently been granted for a 5MW solar farm on a 10.7ha site in West Waterford (Pd 15/614 refers). This solar farm development equates to 2.14ha approximately of land area per MW output. Permission has also been granted for a 28.8ha solar farm in West Waterford, which is currently on appeal, Pd 16/126 refers. The Planning Authority is currently assessing an application for a 12.6ha solar farm south-east of Lismore, Pd 16/371. Permission has been granted for a 5MW solar farm in Pickardstown, Pd 15/770 refers. A planning application has recently been lodged for a solar farm in Kilmeaden, Pd 16/309 refers.

There are a number of pre-planning applications for solar farm development in Waterford which are currently in discussion.

### 5.2 Solar Potential in Waterford

Waterford is in the top 15% in terms of solar resource in Ireland<sup>9</sup> and therefore, subject to rigorous planning assessment, solar energy has good potential in Waterford. See Figure 5.1 below which illustrates the solar irradiation for Ireland.

<sup>8</sup> Fraunhofer ISE (2015): *Current and Future Cost of Photovoltaics. Long-term Scenarios for Market Development, System Prices and LCOE of Utility-Scale PV Systems. Study on behalf of Agora Energiewende.*

<sup>9</sup> Šúri M., Huld T.A., Dunlop E.D. Ossenbrink H.A., 2007. *Potential of solar electricity generation in the European Union member states and candidate countries.*



# Global Horizontal Irradiation (GHI)

Ireland

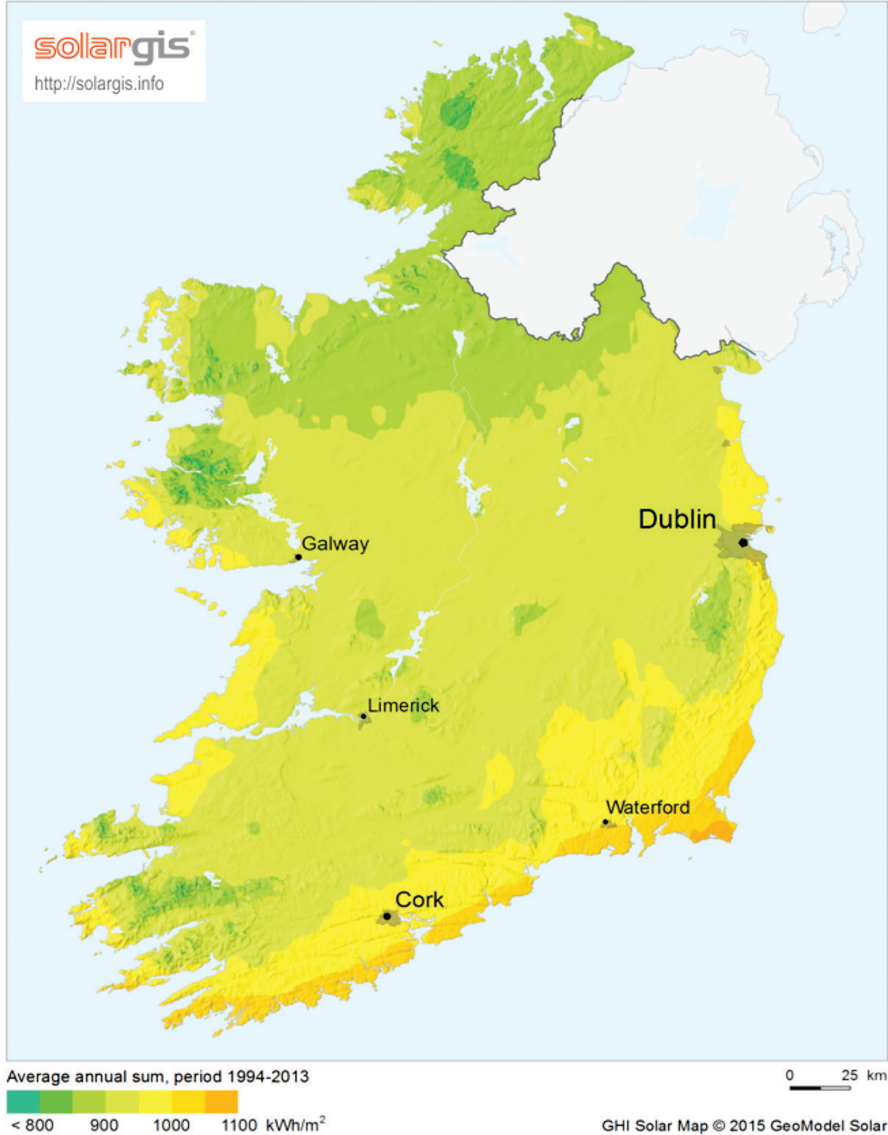



The NREAP sets a national target of 600mW of solar energy to be installed in Ireland by 2020. As a means of meeting this target, a Renewable Energy Feed in Tarriff<sup>10</sup> (REFIT) is expected to be introduced by the DCENR. This Renewable Energy Strategy has included a projection of 84.1MW of solar energy for Waterford up to 2030 – See Table 3.3. This would require a landmass of 168.2ha approximately.

## 5.3 Types of Solar Energy

Solar energy can be captured in two ways:

- Active solar techniques which include the use of photovoltaic panels and solar thermal panels to harness energy;
- Passive solar techniques including orientation of a building towards the sun.

This Strategy will examine the active types of solar energy extraction, i.e. thermal solar panels and photovoltaic.

### 5.3.1 Thermal Solar Panels

Thermal solar panels can be used in buildings for heating/hot water and can make a significant contribution to reducing energy costs. Solar panels, generally located on a south-facing roof, transform the sun's radiation into heat. The heat produced during the day is stored in a large hot water cylinder, so that it can be used at any time. The greater the demand for hot water, the more beneficial solar thermal will be, and the shorter the return on investment. The Greener Homes Scheme run by the SEAI aided the installation of approximately 500 solar systems for domestic purposes in County Waterford between May 2006 and May 2011. Market trends suggest that we will see increased use of solar energy installations in the form of solar panels for domestic and commercial purposes. The Waterford Energy Bureau estimates that there are currently in excess of 1,000 domestic solar installations in Waterford.

### 5.3.2 Solar Photovoltaic

Solar photovoltaic (PV) energy refers to the process by which light from the sun can produce electricity for on-site use or for export of the grid. Solar PV is regarded as a supplementary technology that provides for predictable electricity generation, with limitations on generation being linked to seasonal solar output. There are two main types of solar PV: 1) Grid connected solar PV or 2) Stand alone Solar PV

#### 1. Grid connected Solar PV

A grid-connected PV system is one which connects to the electricity grid and “exports” to the grid. The main advantage of using a grid-connected PV system is that the grid

<sup>10</sup> The Renewable Energy Feed in Tariff (REFIT) schemes/supports are funded by the Public Service Obligation (PSO) which is paid for by all electricity consumers. The REFIT schemes have been designed to incentivise the development of renewable electricity generation in order to ensure Ireland meets its goal of 40% of electricity coming from renewable sources by 2020.

can be used as what is effectively an electricity storage system. In this regard, grid-connected PV systems do not need physical storage systems (batteries) and so the investment cost is reduced.

A “solar farm” is a large scale collection of grid connected solar PV panels used to generate electricity which is exported to the national grid via a substation.

There has recently been a significant decrease in the cost of solar PV panels and this technology should offer possibilities in Waterford up to 2030.

### 1. Stand alone Solar PV

Stand alone PV systems are not connected to the grid. Stand alone systems are set up so that the electricity produced by the PV system is used directly. In order to take full advantage of the electricity produced, it needs to be stored. For this reason, a standalone system will commonly include battery storage. Stand-alone PV systems are very useful where there is no electrical grid connection available and for applications such as street lighting, traffic signs etc.

## 5.4 Advantages/Disadvantages of Solar Energy for Waterford

Advantages	Disadvantages
Good solar radiation	Land take vis a vis energy output
Good Grid connection	Crop production v energy output
Possibility of battery storage for excess energy	Glint/Glare issues
Clean and silent to operate	Possible environmental/hydrological effects

## 6.0 HYDROELECTRIC POWER

Hydroelectric power is power that is derived from the force or energy of moving water, which could be harnessed for the generation of electricity. The amount of electricity a hydroelectric site can generate is dependent on numerous factors including hydraulic head height (the height through which the water falls) and the flow speed of the water. The best sites are those which have large volumes of water all year round, with a large vertical drop in a short distance.

Hydroelectricity is a widely used form of renewable energy. It is considered to be a reliable and generally predictable and consistent source of renewable energy. Once a hydro-electric complex is constructed, the development produces no direct waste, and has a considerably lower output level of carbon dioxide than fossil fuel powered energy plants.

The NREAP envisages a 234MW output from hydro-electricity by 2020. This Renewable Energy Strategy has identified an energy target of 3.1MW from Hydropower in Waterford by 2030 – See Table 3.3.

## 6.1 Hydro Power in Waterford

There are a number of small-scale hydro sites currently operating in Waterford, most notably Mahon river hydro, located outside Mahon Bridge. This site is fed from two weirs, one on the Mahon and the other on the Mahon Óg, about 2 km upstream of the village. The scheme generates a maximum of 850 kW of electricity which is exported to the national grid.

## 6.2 Types of Hydroelectric Schemes

Hydroelectric schemes can be grouped into two broad categories, i.e.:

- Pumped Hydro Electric Storage (PHES);
- Small scale micro-hydro electric scheme.

### 6.2.1 Pumped Hydroelectric Storage (PHES)

A PHES is a method of storing electrical energy as potential energy by pumping water from a reservoir or lake to another reservoir at a higher elevation and storing it for use in generating electricity when required. Pumped Hydro Electric Storage are ideally suited to providing back up to the electrical grid during times of peak / varying demand. The responsive time of pumped storage is quick and the output generated is constant relative to the storage capacity. Turlough Hill in County Wicklow with a storage capacity of 292 MW operates as a pumped hydro electric storage facility and contributes to the balancing of electrical grid demand in the Dublin region. A PHES storage facility is unlikely to proceed in Waterford by 2030.

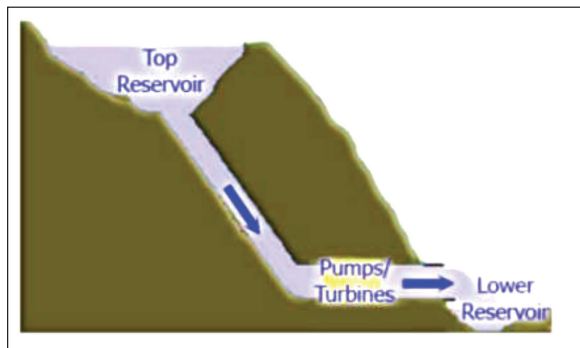

Figure 6.1 Illustration of the operation of a pumped storage hydro system

## 6.2.2 Small-scale Hydroelectric Scheme

Small-scale Hydro refers to hydroelectric plants, typically ranging from 5KW to .5MW. Small scale hydro requires much lower capital investment and is less dependent on location as water can be piped between locations to create the desired head height & flow rates. The geographic features of Waterford are suited to the application of micro hydro sites on a limited basis. The steep courses of many smaller rivers/streams through the Comeragh and Knockmealdown mountains lead to excellent head heights and flow rates which are ideal for small-scale hydro installations. Additionally, the electrical distribution system can be accessed through the foothills of the mountains, allowing for many potential sites to be readily connected to the existing infrastructure.

## 6.3 Hydroelectric Potential in Waterford

Due to its upland areas and fast flowing streams and rivers there is potentially an unexploited hydroelectricity resource available in Waterford, particularly in terms of micro-hydro electricity. The RES has identified two types of micro hydro-schemes which are likely to progress in Waterford in the future;:

1. Hydroelectric schemes at old mill sites that can be retrofitted with hydroelectric turbines, providing a new function for these obsolete buildings. Refurbishment/rehabilitation of these mills offers possible potential for commercial development and may be more economically attractive than the development of greenfield sites. In many cases the characteristics of old water mills are favourable to hydro-electric scheme development with a good water head height and favourable water flow rates. One of the pillars of Waterford's industrial wealth during the late 18th/19th Century could be attributed to use of hydro power from interalia the Clodiagh, the Bride and the Mahon Rivers. In many cases, the buildings and mill races still exist and subject to more detailed assessment, offer potential for harnessing hydro electric power.
2. New hydroelectric schemes at green field sites that have the necessary favourable characteristics and can be fed by streams and river water sources.

## 6.4 Advantages/Disadvantages of Hydroelectric power for Waterford

Advantages	Disadvantages
Low operating costs.	Can have environmental impact such as disruption of fish life/ecological systems
Technology can be used as an energy storage mechanism.	Significant water flow and volume required to generate electricity.

<p>Energy output can be easily managed according to demand.</p>	<p>Possible environmental/hydrological effects. Can affect surface water hydrology due to over abstraction resulting in damage to fish stocks or water flow.</p>
<p>Proven technology and long life cycle</p>	<p>Risk to biodiversity.</p>

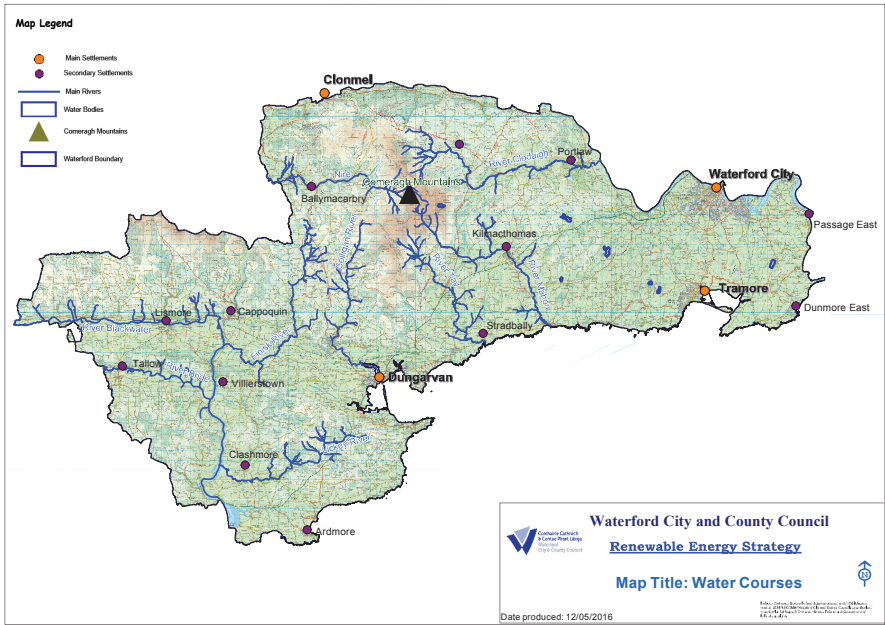

Figure 6.2 Watercourses in Waterford

## 7.0 BIOENERGY





Bio-energy can be defined as the energy derived from biomass. The three main categories of bio-energy are biomass, bioliquids and biofuels.

Biomass is formed by the biodegradable fraction of products, waste and residues from agriculture (including vegetal and animal substances), forestry and related industries including fisheries and aquaculture. As well as the biodegradable fraction of industrial and municipal waste, it also includes energy crops such as oilseed rape and willow etc.

Bioenergy is likely to play a significant role in the growth of the renewable energy sector, particularly in the areas of heat and transport, stimulating local economic activity<sup>11</sup>. The Bio-Energy Implementation Plan for the South-East identifies the bio-energy resources for the region and opportunities for their development. It is a target of the Plan that 17% of total energy supply in the south-east will come from biomass by 2020<sup>12</sup>.

Bio-energy technologies have the potential to contribute towards renewable energy targets for heat, electricity and transport in the domestic, commercial and industrial sectors. This Renewable Energy Strategy has identified an energy target of 202MW from Bioenergy for Waterford by 2030 – See Table 3.3.

Examples of bio-energy technologies include:

- Wood log stoves and boilers;
- Wood log gasification boilers;
- Woodchip/pellet boilers;
- Combined heat and power (CHP) plants;
- Anaerobic Digestion Plants.

## **7.1 Bio-energy Development in Waterford**

There are a number of bio-energy developments in Waterford. One of the larger scale developments relates to GlaxoSmithKline industrial plant in Dungarvan. Currently, a woodchip boiler is being constructed on site which will be fired from local forestry thinnings [192 tonnes of woodchip will be required per week]. It will have a capacity of 4MW and is expected to produce 6.1 tonnes of steam per hour. This installation will largely replace the current oil boilers being used and will assist GlaxoSmithKline to diversify its energy supply, reduce energy costs and thereby improve its competitiveness.

---

<sup>11</sup> National Renewable Energy Action Plan (NREAP) and the Strategy for Renewable Energy 2012 – 2020.  
<sup>12</sup> South-East Regional Authority – South-East Bio-Energy Implementation Plan 2013-2020



## 7.2 Bioenergy Potential in Waterford



### 7.2.1 Wood energy

The utilisation of forestry has the highest potential growth for biomass production in Waterford. Currently 29,316ha approximately of land in the county is devoted to forestry which equates to nearly 16% land cover. The majority of the resource is located in the north and west of the county, centred close to Clonmel and Lismore/Dungarvan respectively (See Figure 7.1 below).

County	Total (ha)	Private (ha)	Public (ha)	Total land area of county (ha)	% of County Planted
Waterford	29,316.67	10,623.23	18,693.44	183,786	15.95%
Cork	90,837.05	41,991.83	48,845.22	745,988	12.18%
Kilkenny	20,867.73	10,765.71	10,102.02	206,167	10.12%
Tipperary	51,433.04	23,012.79	28,420.25	425,458	12.09%
Wexford	16,390.55	7,755.01	8,635.54	235,143	6.97%

Table 7.1 Forestry Cover by County [Source: Forest Service 2012 Annual Report]

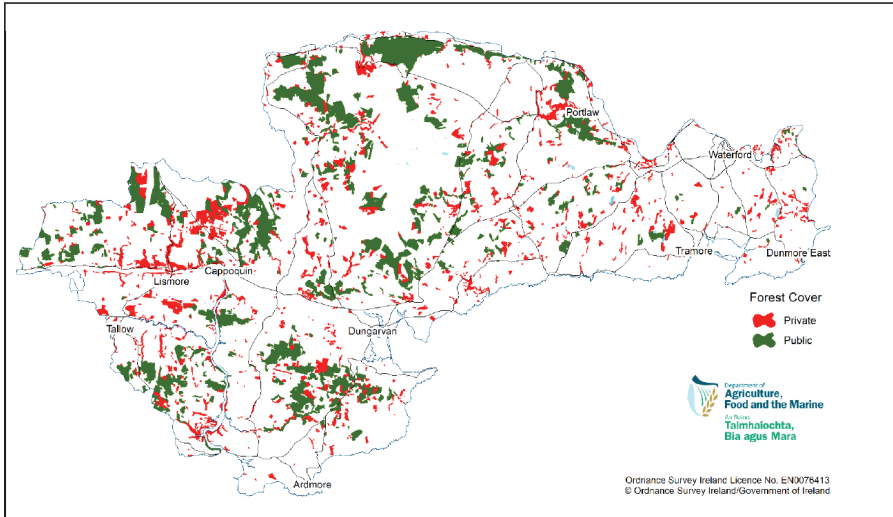

Figure 7.1 Public and Private Forestry in Waterford [Source: Teagasc]

Forestry resources such as clear felling, clear felling logging residues and shredding, forestry stump wood, forestry thinnings, and residues from forestry thinnings all can be utilised where feasible for the generation of heat and electricity in a range of suitable processes. At present, only 18% of the forestry thinnings generated in Waterford are utilised, largely at the two wood processing plants in the south-east, namely in Clonmel and Waterford Port.

This RES recognises that an increase of the forestry biomass resource can be achieved in a very short time frame without the need for any increase in overall plantations by setting up an alternative market for this resource. By harvesting the existing thinning resource and utilisation of the forestry waste products available, many new jobs could be created in this industry by simply managing the resources available in a more efficient manner. Waterford Forestry Owners Group was formed by TEGASC in 2011 as a means of managing the forestry resource in Waterford which is increasing year on year, requiring additional end markets to maximise this forestry potential.

Factors which will influence the decision to carry out thinning of woodland include the provision of access to the plantations from the public road. In County Waterford, this will require a more targeted approach to identify the location of access routes, in consultation with the relevant forestry bodies such as Waterford Forestry Owners Group to ensure that forestry plantations are accessible.

With transport costs being a critical viability factor in the biomass industry, Waterford could develop sustainable supply/demand clusters for wood biomass close to main centres of population, thereby securing viable route to market. International best practice highlights that biomass used for energy purposes should be grown within 100 KM of where it is used. The following table illustrates the forestry biomass potential upto 2030:

Waterford's Forestry Resource		2020 Resource		2030 Resource	
Crop type	Land Area (Hectares)	% of Resource Available for Heat/ Electricity	Annual Resource Available for Heat/ Electricity (GWh)	% of Resource Available for Heat/ Electricity	Annual Resource Available for Heat/ Electricity (GWh)
<b>Forestry (public)</b>					
<i>Clear-felling</i>	2,453	2.00%	31.28	2.00%	31.28
<i>Clear-felling logging residues, bundling and shredding</i>	2,453	0.00%	0.00	50.00%	354.52
<i>Forestry Stump Wood Extraction</i>	2,453	0.00%	0.00	20.00%	166.83
<i>Forestry Tinnings</i>	5,643	18.00%	120.87	50.00%	335.75
<i>Forestry Residues from Thinnings</i>	5,643	0.00%	0.00	20.00%	95.93
<b>Total</b>	<b>18,646</b>		<b>152.15</b>		<b>984.31</b>
<b>Forestry (private)</b>					
<i>Clear-felling</i>	1,348	2.00%	17.18	2.00%	17.18
<i>Clear-felling logging residues, bundling and shredding</i>	1,348	0.00%	0.00	50.00%	194.71
<i>Forestry Stump Wood Extraction</i>	1,348	0.00%	0.00	20.00%	91.63
<i>Forestry Thinnings</i>	3,099	18.00%	66.39	50.00%	184.41
<i>Forestry Residues for Thinnings</i>	3,099	0.00%	0.00	20.00%	52.69
<b>Total</b>	<b>10,241</b>		<b>83.57</b>		<b>540.62</b>

Table 7.2 Forestry Biomass potential in Waterford up to 2030 [Source: Waterford Energy Bureau]

## 7.2.2 Energy crops

The growth of energy crops such as oilseed rape, miscanthus and willow has had limited uptake in County Waterford.

When crops are grown for biomass purposes many factors must be considered, such as availability of land and the profitability of the crop, as many crops, such as oilseed rape or miscanthus utilise farmland which would otherwise have been designated for food production. Some crops, such as Willow can be cultivated on marginal lands which would not otherwise be suitable for agriculture, but the availability of such sites is limited.

In the medium term from 2016 to 2030, this Strategy recognises that energy crops will have a limited contribution to make in the provision of energy in the form of heat and electrical generation and will only become viable with more favourable market conditions.

## 7.2.3 Solid Biomass Combined Heat & Power

Combined Heat & Power can be powered by a number of resources, namely solid biomass, natural gas and biogas.

Solid biomass CHP installation powered by forestry and energy crops has significant potential for replication in Waterford where thermal energy in the form of steam or conventional heating can be used to heat buildings / processes. The electricity generated on site can be exported to the national grid or can be used for an industrial process. Each CHP plant provides heat and electricity on site in a single process using waste timber and forestry thinnings as the main feed source.

The use of forest-based biomass can improve the overall energy efficiency of industrial landuses. For example, Aurivo Milk Processing Plant in Ballaghaderreen, Co. Roscommon installed a biomass CHP plant in 2014 using forest based biomass. This has improved the overall energy efficiency of the plant and is a template that could be replicated at a number of locations in Waterford on a smaller scale.

The most advantageous locations for biomass CHP are:

- Areas not linked to the national gas grid, e.g. Dungarvan, Lismore;
- Locations with high annual thermal energy demand, e.g. industrial estates, hospitals;
- Locations where biomass resource is readily available to be utilized, e.g. West Waterford.

There is potential within Waterford to develop a number of biomass CHP installations, which can be linked to district heating schemes (see Section 7.3). Large urban areas with industrial estates such as Dungarvan, Cappoquin are suited to biomass CHP as there is adequate space to accommodate such a facility and excess heat generated can be used to service adjoining industries or even hospitals. In the Nordic countries the presence of a biomass CHP plant is a beneficial piece of infrastructure that can be utilised to

attract businesses and industry with the offer of the supply of a cheap source of heat and electricity. There is potential to replicate this model in Waterford.

## 7.2.4 Biogas (Anaerobic Digestion)

Anaerobic Digestion facilities are common throughout the European Union and have many environmental benefits. AD facilities use bacteria to convert organic material such as sewerage sludge, industrial / houses hold waste, agricultural wastes and energy crops such as maize into biogas. AD offers potential for the generation of electricity and heat through the burning of biogas in a localized CHP plant.

### Case Study: Council operated AD facility at Kilbarry, Waterford

The Council are in the process of building an AD facility at Kilbarry, Waterford City with the main feed stock being organic brown bin collections, solid and liquid industrial waste. A CHP plant will form part of this facility with the heat generated from the CHP being used to heat the AD feed tanks and excess heat being used to dry wood chip. Electricity generated will be exported to the Grid. The CHP will operate approximately 8,000 hours per year and solid fertilizer will be produced as part of the process. The main feed stock to the AD facility will be organic brown bin waste, solid and liquid industrial waste.

There has been limited investment in AD facilities at a farm level in Waterford to date. However, Climate Change obligations and national energy targets could result in an increase of such facilities, as the burning of methane in an AD facility could significantly reduce greenhouse gas emissions from agriculture.

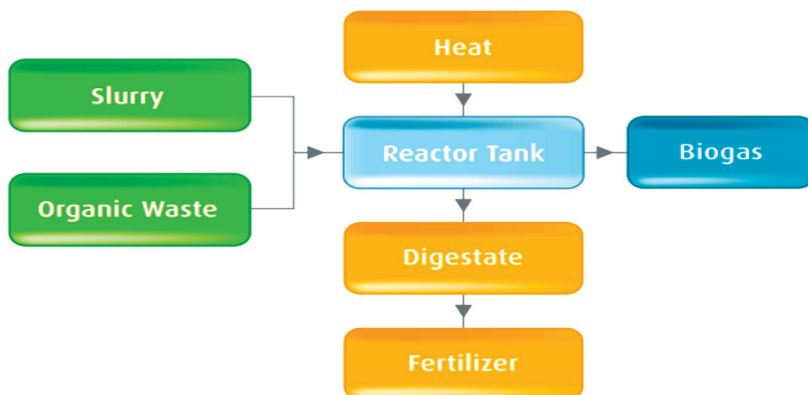

Figure 7.2 Anaerobic Digestion Diagram [Source: South-East Bio-Energy Implementation Plan 2013-2020]

## 7.2.4.1 Anaerobic Digestion Potential in Waterford

This Strategy considers that there are two types of AD facilities which have potential in Waterford in the future:

- Agricultural AD facility, whereby slurry is used as a feedstock for Anaerobic Digestion. Such an installation is likely to be farm based and is likely to progress where there is an abundant and constant supply of raw material (i.e. slurry) to feed the AD facility.
- Industrial AD facility, where the feed stock is likely to be a mixture of sewerage sludge, industrial / houses hold waste, agricultural wastes and energy crops such as maize. Such installations are likely to be based within an industrial estate or other strategic location.

## 7.3 District Heating Schemes

District heating (DH) schemes involve a network of heating distribution pipes in a local area which generate hot water / steam and service a range of buildings. The localised production and use of heat from renewable energy resources as set out in the NREAP is essential for Ireland to reach its overall legally binding target. District heating schemes can be based on a variety of technologies and renewable energy sources, such as combined heat and power (CHP), biomass energy, geothermal or energy from waste.

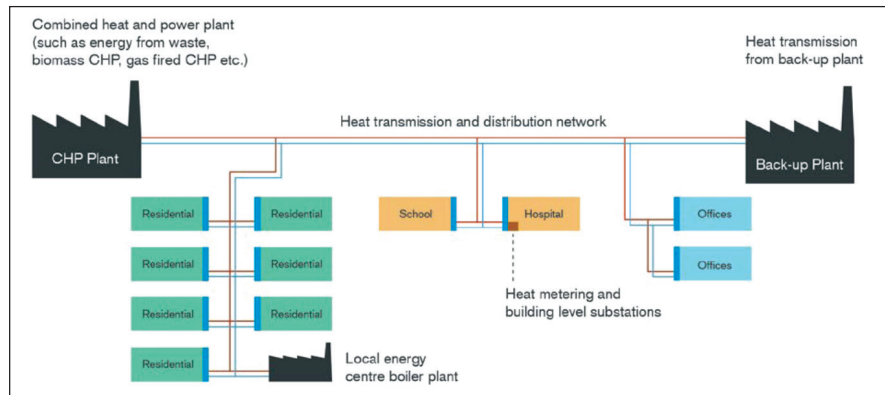

Figure 7.3 District Heating scheme example. (source: [www.londonheatmap.org.uk](http://www.londonheatmap.org.uk))

### 7.3.1 District Heating in Waterford

A Biomass District Heating Feasibility study for Dungarvan was completed in 2009 and highlighted a number of suitable locations such as the IDA Industrial Estate, where DH schemes typically powered by locally grown forestry thinnings and miscanthus may be viable with funding.

### 7.3.2 District Heating Potential in Waterford

Biomass DH schemes in particular have potential for development in areas not linked to the natural gas network and where there is a substantial local resource available to be utilised. Urban areas with a range of local heat demands in excess of 4000 hours per year are best suited to this infrastructure, e.g. Dungarvan, Lismore, Cappoquin.

### 7.4 Advantages/Disadvantages of Bioenergy for Waterford

Advantages	Disadvantages
<ul style="list-style-type: none"> <li>Abundant and renewable – forestry resources close to centres of population in Waterford.</li> </ul>	<ul style="list-style-type: none"> <li>Large amounts of land required to harvest energy crops to become viable.</li> </ul>
<ul style="list-style-type: none"> <li>Can be used to burn waste products.</li> </ul>	<ul style="list-style-type: none"> <li>Equipment installation is expensive.</li> </ul>
<ul style="list-style-type: none"> <li>Can be integrated into existing infrastructure.</li> </ul>	<ul style="list-style-type: none"> <li>Long term strategy required to ensure fuel supply.</li> </ul>
<ul style="list-style-type: none"> <li>Employment opportunities.</li> </ul>	<ul style="list-style-type: none"> <li>Significant investment required in biomass supply chain.</li> </ul>
<ul style="list-style-type: none"> <li>Alternative market for product which might otherwise be unused.</li> </ul>	<ul style="list-style-type: none"> <li>Limited to rural communities.</li> </ul>

Table 7.3 Advantages/Disadvantages of Bioenergy for Waterford

## 8.0 MARINE RENEWABLE ENERGY

### 8.1 Introduction & background

Ocean energy refers to electrical energy extracted from waves and tidal movements. The term ‘marine renewable energy’ typically refers to wave, tidal and offshore wind.

The offshore energy resource off the coast of Waterford has the potential to offer a considerable source of renewable energy. The Ocean Renewable Energy Development Plan 201413 designates the Waterford coastline as part of Area 3 (South coast) – See Figure 8.1. Area 3 is stated as having the potential to generate up to 7,800MW of energy from offshore wind. The OREDP Plan did not cover tidal or wave energy as part of its assessment of the energy potential for the south coast as much of the focus to date for tidal, and wave energy in particular, has been concentrated off the west coast of Ireland where there are a number of test sites. However, that is not to say that wave and tidal energy would not have a role to play off the Waterford coast in the future.

<sup>13</sup> DCENR *Ocean Renewable Energy Development Plan A Framework for the Sustainable Development of Ireland’s Offshore Renewable Energy Resource* February 2014



This Renewable Energy Strategy has set a target of 43MW energy output from marine renewable energy by 2030 – See Table 3.3.

Marine renewable energy as a whole is seen as a medium to long term technology which can contribute significantly to Ireland’s renewable energy targets. It is anticipated that the government will continue to make funding available to assist in the development of this technology.

Development planning and, in particular, foreshore lease policies, are critical enabling factors for the development of offshore renewable energy. The Foreshore (Amendment) Bill in 2011 provides significant opportunity to local authorities for increased engagement in the creation of an efficient planning consent system for marine energy development. Waterford City & County Council has a role to play in this regard and can position itself to manage development of marine energy off the Waterford coast when the Bill is enacted (anticipated during the lifetime of this strategy).

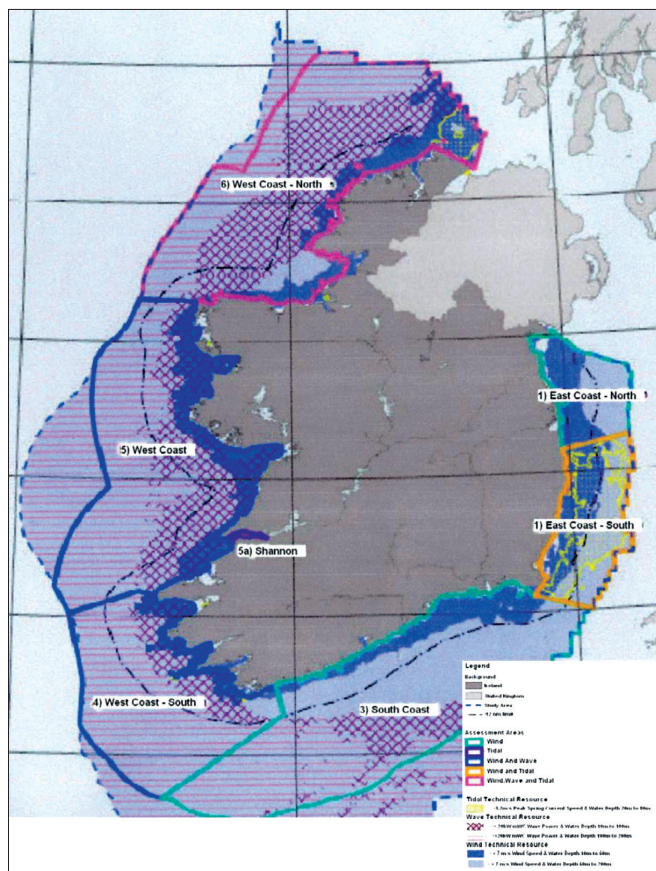

Figure 8.1 Marine Renewable Energy Indicative Development Zones [Source: OREDP 2014]



## 8.2 Offshore Wind

Offshore wind is the most technically advanced of the marine renewables although it is still largely at a development stage in Ireland. The only offshore wind farm constructed to date is the Arklow Bank Project off the East coast although there are a number of companies currently involved in the development of offshore wind energy projects in Ireland<sup>14</sup>. Offshore wind presents challenges in terms of construction costs, grid connection, development planning and visual/environmental impacts, requiring the input of a wide range of stakeholders.



### 8.2.1 Offshore Wind Potential in Waterford

The OREDP recognises the potential of fixed and floating wind turbine structures off the South Coast of Ireland, including Waterford. Fixed turbines (i.e. turbines constructed on the seabed) are typically suited to a seabed depth of up to 50m. Floating turbines are most suited thereafter – See Figure 8.2. In terms of seabed depths along the Waterford coast, a depth of up to 50m would cover a distance of 8km approximately from the coastline. Figure 8.3 illustrates the seabed depths along the Waterford coast.

<sup>14</sup>

National Offshore Wind Energy Association of Ireland, <http://www.nowireland.ie>

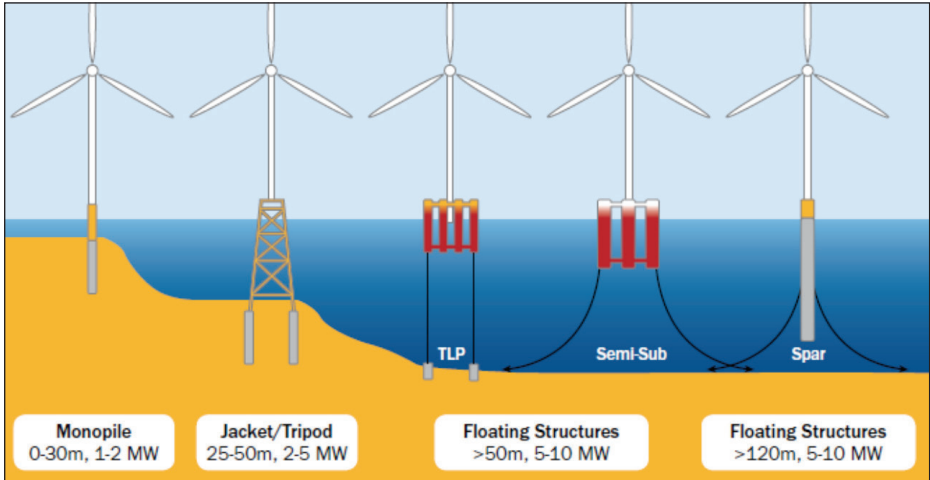

Figure 8.2 Offshore wind foundations [Source: European Wind Energy Association 2013]

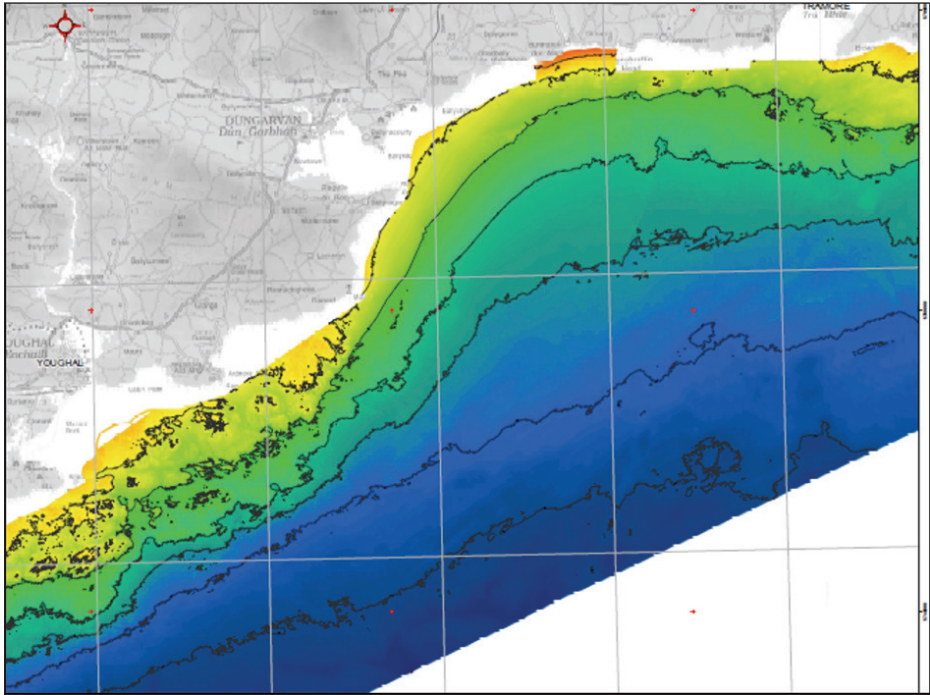

Figure 8.3 Seabed depths off the Coast of Waterford [Source: INFOMAR]

## 8.3 Tidal energy

The two main types of tidal energy are:

1. Tidal barrage system is a dam-like structure used to capture the energy from a body of water moving in and out of a bay or river due to tidal forces. They are unlikely to be a viable option for Waterford due to environmental considerations when installing the system.
2. Tidal stream turbine is located beneath the water surface and operate on the same principal as a wind turbine, driven by consistent tidal currents. They appear to be the most viable option for replication in Waterford.

The major benefit of tidal energy is the predictability of tidal streams which is highly attractive for grid management and load profiles.

### 8.3.1 Tidal Energy in Waterford

Historically, tidal energy was one of the first forms of renewable energy utilised in Waterford, with evidence of a 5th century tidal mill being discovered at Kiloteran and the remains of many more 18th and 19th century mills still visible in places such as Piltown, Cheekpoint and Dungarvan. Today, tidal energy represents one of the most exciting emerging forms of renewable energy. There have been no tidal energy installations off the Waterford coast to date.

### 8.3.2 Tidal Energy Potential in Waterford

The SEAI report on Tidal Current Energy Resources in Ireland<sup>15</sup> shows that although some coastal areas of Waterford fulfil the topographic requirements for an installation of the first phase of tidal energy technologies, the overall average tidal current falls below the established working parameters for efficient generation. However, there is a possibility of tidal energy being developed in Waterford in the future when the technology efficiency improves. The SEAI recommend that a re-assessment of tidal energy viability be undertaken after a period when further test data is available. This Strategy is supportive of Waterford being a location for research and development of tidal technology.



15 Sustainable Energy Authority of Ireland, *Tidal and Current Energy Resources in Ireland*, 2008



## 8.5 Advantages/Disadvantages of Marine Renewable Energy for Waterford

The following is a summary of the advantages and disadvantages pertaining to Marine Renewable Energy for Waterford.

Advantages	Disadvantages
<ul style="list-style-type: none"> <li>Abundant resource, clean, and safe</li> </ul>	<ul style="list-style-type: none"> <li>Technology is still not cost effective and more technological advancements are required to make it commercially viable.</li> </ul>
<ul style="list-style-type: none"> <li>Tides are very reliable with predictable generation output</li> </ul>	<ul style="list-style-type: none"> <li>Shipping and navigation could be disrupted</li> </ul>
<ul style="list-style-type: none"> <li>Visual aspects possibly reduced compared to onshore development.</li> </ul>	<ul style="list-style-type: none"> <li>Expensive technology to install - will require subsidies</li> </ul>
<ul style="list-style-type: none"> <li>Employment opportunities and business development</li> </ul>	<ul style="list-style-type: none"> <li>Significant infrastructure requirement</li> </ul>
	<ul style="list-style-type: none"> <li>Impacts on marine life</li> </ul>
	<ul style="list-style-type: none"> <li>Limited power production at present</li> </ul>
	<ul style="list-style-type: none"> <li>Output of some technology limited to periodic generation such as tides.</li> </ul>

## 9.0 MICRO RENEWABLE ENERGY GENERATION

There are many definitions for micro-energy generation. However, for the purposes of this Strategy, and as per Electric Ireland (EI) definition, micro generation is defined as grid connected electrical generation up to a maximum output of 11kW. Most domestic users are only capable of having a micro generation facility of a rating up to 5.75 kW output to the grid.

Micro generation also applies where energy is generated and consumed on site, and not exported to the electrical grid. This concept of energy generation is understood as zero or low carbon heat and power generated by individuals, businesses or communities to serve their individual energy needs.

Micro generation renewable energy technologies can include:

- Solar photovoltaic
- Solar water heating

- Micro wind turbines
- Micro hydro electrical schemes
- Micro scale biomass stoves and boilers
- Ground / air source heat pumps
- Micro CHP plants

## **9.1 Micro Renewable Development in Waterford**

Examples of micro-generation technology in Waterford include the use of wind turbines at the civic amenity sites in Dungarvan and Tramore, and solar panels at the Holy Ghost care home, Waterford City. Also, many private dwellings in Waterford have erected solar panels or to a lesser degree some have installed single wind turbines on their property.

## **9.2 Micro Renewable Potential in Waterford**

Low carbon development, through use of micro renewable energy technologies will be encouraged throughout Waterford having regard to the principles of proper planning and sustainable development. Micro-renewable energy presents many benefits including reduced dependency on fossil fuels thereby enhancing fuel security and positively impacting on CO2 emissions. Other benefits include reduced energy costs and increased competitiveness.

Many micro-renewables serving domestic, industrial, commercial or agricultural purposes are exempt from planning permission under certain conditions. Regard should be had to the following publications which detail the type of micro-renewables which are exempt from planning permission:

- Domestic Renewable Energy Installations - SI 83 Planning & Development Regulations 2007 (as amended);
- Commercial/Agricultural Renewable Energy Installations - SI 235 Planning & Development Regulations 2008 (as amended).

Any proposals for micro-renewables that require planning permission will be determined in accordance with the principles of proper planning and sustainable development, and the relevant policies of the City/County Development Plan.

Micro Combined Heat & Power (CHP) units have been piloted by SEAI in 2011 with some favourable results and offer potential where there is a hot water demand above 4000 hours a year and where there is a constant electrical demand or where there is a favourable REFITT tariff. Further support schemes are expected to support the roll out for micro CHP are where commercial, large residential buildings etc, will have micro CHP installed.

### 9.3 Advantages/Disadvantages of Micro Renewable Energy Generation for Waterford

Advantages	Disadvantages
<ul style="list-style-type: none"> <li>• Produces little or no water/air pollution</li> </ul>	<ul style="list-style-type: none"> <li>• Some visual impact</li> </ul>
<ul style="list-style-type: none"> <li>• Can be located relatively close to end user.</li> </ul>	<ul style="list-style-type: none"> <li>• Little capacity for storage</li> </ul>
<ul style="list-style-type: none"> <li>• Easily scalable system</li> </ul>	<ul style="list-style-type: none"> <li>• Expensive technology to install, grant assistance required in many cases</li> </ul>
<ul style="list-style-type: none"> <li>• Employment and income opportunity to rural communities in particular</li> </ul>	<ul style="list-style-type: none"> <li>• Live cycle and maintenance issues are a concern for some technologies</li> </ul>
<ul style="list-style-type: none"> <li>• Reduces loading of national grid requirements</li> </ul>	<ul style="list-style-type: none"> <li>• Micro renewables are not favoured by large utility companies</li> </ul>
<ul style="list-style-type: none"> <li>• Reduced energy costs</li> </ul>	<ul style="list-style-type: none"> <li>• Output of some micro renewable varies with environmental conditions</li> </ul>

## 10.0 MISCELLANEOUS RENEWABLES

### 10.1 Geothermal Energy

Geothermal energy seeks to harness energy through the extraction of power from heat stored in the earth. There are two forms of geothermal installation, namely deep or shallow pipe installations. In general, the potential impacts that may arise are more significant in cases where deep installations are proposed. Deep geothermal typically involves drilling in excess of 400m below the earth's surface.

#### 10.1.1 Geothermal Energy Development in Waterford

There are approximately 300 shallow geothermal installations in Waterford where heat is extracted from a ground source and upgraded via a heat pump and distributed into a building to provide space heating.

#### 10.1.2 Geothermal Energy Potential in Waterford

Deep geothermal energy for heat and electricity generation is unlikely to progress in Waterford pre 2030 as other alternative forms of renewable energy are deemed more

economically advantageous. The high capital costs of accessing this resource renders it unfavourable.

The potential for the further use of this technology for home heating is not significant due to improvements in efficiencies of air-source heat pumps which now have an improved coefficient of performance (COP), making air-source heat pumps a more favourable option for many building projects due to lower installation costs. A target of 124MW of energy output from domestic micro thermal including heat pumps, micro CHP, solar water heating is envisaged in this Renewable Energy Strategy for Waterford by 2030.

### 10.1.3 Advantages/Disadvantages of Geo-thermal for Waterford

Advantages	Disadvantages
<ul style="list-style-type: none"> <li>• Low running costs</li> </ul>	<ul style="list-style-type: none"> <li>• Possible seismic events and subsidence</li> </ul>
<ul style="list-style-type: none"> <li>• Little or no pollution (if gases contained)</li> </ul>	<ul style="list-style-type: none"> <li>• Possible toxic chemical run-off</li> </ul>
<ul style="list-style-type: none"> <li>• Consistent and reliable power generation</li> </ul>	<ul style="list-style-type: none"> <li>• Exploration and drilling very expensive</li> </ul>

## 10.2 Combined Heat and Power – Natural Gas

As modern industries strive to become more fuel efficient CHP is often seen as a practical addition, providing on-site heat and electricity. Leisure centres and Hotels with swimming pools have a requirement for continuous heat generation and CHP plants are ideally suited to such facilities.

### 10.2.1 Natural Gas CHP in Waterford

Examples of functioning CHP boilers which are powered by locally available natural gas can be found at Crystal Leisure, the Kingfisher Club, the Woodlands Hotel, and the Tower Hotel.

### 10.2.2 Natural Gas CHP Development Potential in Waterford

There is limited scope for further gas fired CHP installations in Waterford and will be site specific and will tend to be units that are sized to match specific processes. An energy output of 2.6MW from Natural Gas CHP is envisaged in this Renewable Energy Strategy by 2030 – See Table 3.3. The White Paper “Ireland’s Transition to a Low Carbon Energy Future” is supportive of future CHP installations between 2015-2030.



## 11.0 RENEWABLE TRANSPORT TECHNOLOGIES

### 11.1 Transport

The transport sector is the largest fuel consumer in Ireland and is responsible for more greenhouse gas emissions than any other sector of the economy. The achievement of a 10% transport target from renewables by 2020 is ambitious and one which will require significant measures to achieve. In 2014 renewable energy accounted for 5.2% of transport energy consumption in Ireland<sup>18</sup>.

The White Paper for Energy 2015 is cognisant of the need to support alternatives to fossil fuels for transport and it recommends the following initiatives:

- The roll out of electric and gas vehicles through grants and tax relief, and;
- Development of a national policy framework to support infrastructure for alternative transport fuels.

In this regard, a combination of energy efficiency transport initiatives, electric vehicles and renewable transport sources can reduce Waterford's dependence on imported fossil fuels and associated greenhouse gas emissions from the transport sector.

### 11.2 Electric Vehicles

The carbon emissions relating to the powering of electric vehicles<sup>19</sup> is expected to reduce significantly by 2030, through the adoption of electrical generating renewable technologies and more efficient generating plant and Smart Grid technology.

#### 11.2.1 Electric Vehicle Development in Waterford

The ESB is responsible for the rollout of EV charging points across the country with 3 types of charge points being installed by 'ESB ecars' nationwide: home charge points, public charge points and fast charge points. Currently, there are sixteen EV charge points located in Waterford city and county. Waterford City and County Council purchased a number of electrical vehicles under the Dungarvan Smarter Travel Programme which are used for work purposes around Dungarvan and environment and have proved a credible, effective form of transport.

#### 11.2.2 Electric Vehicle Potential in Waterford

The Council supports the expansion of the EV charging network in Waterford in conjunction with the ESB and will seek to require the installation of additional public

<sup>18</sup> SEAI *Energy in Ireland Key Statistics 2015 (2015)*

<sup>19</sup> "As of September 2015, the number of EVs in Ireland was over 1000. Meeting the 2020 target would mean that EVs would account for 20% of all new cars sold in Ireland by 2020". SEAI report 2016

charge points<sup>20</sup> as part of car-parking facilities of private developments through its development management standards for car-parking as set out in the City & County Development Plan (as varied).

## **11.3 Biofuels**

The national Biofuel Obligation Scheme 2010 requires all road transport fuel suppliers to use biofuel in the fuel mix (6% since January 2013) with a further target of just over 8.5% being adopted from January 2017. This scheme is recognised as the most promising means of securing national renewable energy targets by 2020. However, under this scheme much of the biofuel is imported.

### **11.3.1 BioFuel Potential in Waterford**

There is a need to support and develop indigenous renewable energy sources that contribute to meeting the transport renewable energy targets. The potential exists for the development of second generation biofuel production facilities which will produce more advanced biofuels within Waterford. Such a development would likely be developed by a private company, requiring significant resources to develop such a facility.

Bio-ethanol<sup>21</sup> has potential for use as a direct petrol supplement within vehicles. This is particularly the case where the ethanol is produced from residues of dairy products, thereby creating potential spin-off economic opportunity in the dairy sector in Waterford.

## **12.0 SUPPORTING INFRASTRUCTURE**

### **12.1 Introduction**

The maximising of the renewable energy potential of Waterford up to and beyond 2030 is dependent on the installation of local and national key infrastructure, which includes the national electrical transmission and distribution network, national gas network, transportation system within the county and other services / utilities such as water and wastewater.

Developing renewable energy projects will have different infrastructure requirements depending on the technology employed, the location and the operation conditions. These include access and connection to grid infrastructure, distribution networks, accessibility (by road, rail, or sea), ports/yards for crane installation and component assembly and access routes for decommissioning, operation and maintenance.

---

<sup>20</sup> There are approximately 16 EV charge points in Waterford City & County - May 2016

<sup>21</sup> Bioethanol is a type of fuel made from plants and can be used as an alternative to petrol - [www.oxforddictionaries.com](http://www.oxforddictionaries.com)

## **12.2 Grid Connection**

Large renewable energy projects are required to make a connection to the grid. Viability of grid connection is a very important planning consideration. It may be that a site is a considerable distance from the network or that the network is unable to handle extra capacity potential. In such cases, network improvements may be required or additional overhead lines may be required which could result in issues regarding visual impacts/prohibitive costs.

Since December 2004, a Group Processing Approach (GPA) has applied to applications for connection offers for large renewable electricity generators (mostly wind) to the national grid.

Under the GPA (Group Processing Approach) or 'Gate' process, applications for connections to the grid are processed in batches rather than sequentially. To date there have been three Gates. Under Gate 1 and Gate 2, 1,755 MW of connection offers were made and accepted. Grid offers are currently being exercised for projects under the Gate 3 grid access process which provides for almost 4,000 MW of new renewable energy generation nationally. Future renewable energy projects are likely to be offered under the Gate 4 grid access process. The expected date for grid offers to be made under Gate 4 projects is not known but is likely to be post 2020. See Appendix 3 for a list of current Grid applications in Waterford.

The Grid 25 Strategy published in 2008 and which makes provision for the future infrastructure required to deliver Gate 3 renewable energy projects, is now currently under review. It will be superseded by a new national Grid Development Strategy to be published in 2016. This new Strategy incorporates the 'Regional Option' which proposes to use the existing 400kV grid infrastructure from Moneypoint to the greater Dublin Area, the exact details of which are still being worked on.

The Council is committed to working closely with Eirgrid in the preparation of this Grid Development Strategy to ensure that the County has the required infrastructure network to enable it to generate, distribute and export renewable energy.

## **12.3 Electricity Supply Network**

There is no conventional electrical generation plant in Waterford, the nearest plant being the 460 MW gas fire plant at Great Island Wexford.

Waterford is serviced by a 220 kV and 110 kV electrical transmission network. Both these transmission lines are linked to strategically located transformer sub-stations where the voltage is reduced to 38kV and eventually to the 20 kV lines for onward local distribution.

Renewable energy projects depending on scale will access the electrical grid via the 110kV, 38kV and 20kV lines through the building of a substation / transformer point, with micro renewables accessing the distribution network directly through the available electrical service.

Eirgrid manages and operates the national 400 kV, 220 kV and 110 kV electrical transmission network throughout Ireland and two electrical interconnectors. The 38kV and 20kV distribution network which spans the whole of Waterford is managed by ESB Networks.

Additional support infrastructure including substations, transformer points, power lines will likely be required, between 2016-2030 to cater for the additional electrical demand, which this Strategy has identified to increase at a rate of between 6% - 7% per year up to 2030.

## **12.4 Gas Network**

Gas Networks own and operate the natural gas transmission and distribution network in Ireland which currently services Waterford City and Tramore along with a connection for future development in Kilmeaden. An increase to the gas network within these areas will help provide security of gas supply to industry / homes etc. Modifications to the existing gas network will be required to accommodate the powering of natural gas vehicles and for the injecting of processed biogas into the gas distribution network.

## **12.5 Smart Grid**

The development of a smart grid is an important energy efficiency measure and a means of maximising the benefits of renewable energy technologies exporting to the grid. Criteria of the Smart Grid include:

- Voltage / grid power management;
- Integration of the expansion of electric transport system;
- Demand side management;
- Smart metering for all sectors;
- Sophisticated tariffs. will significantly contribute to the development of a smart grid by 2030.

The Council fully supports the evolution of the current electricity grid to meet the criteria outlined above and to better deliver energy to Waterford.

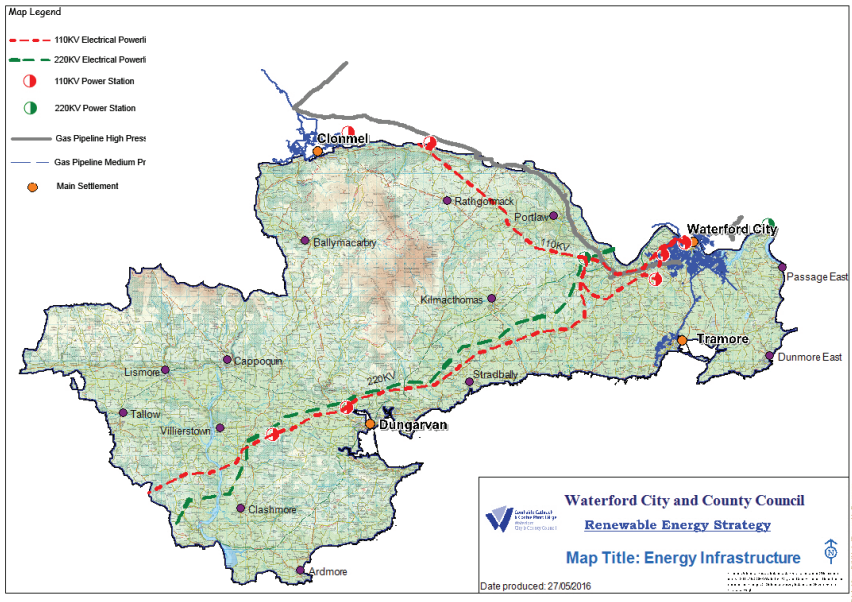

Figure 12.1 Energy Infrastructure in Waterford

## 12.6 Road Network

The quality of the road network is imperative to developing renewable energy projects in Waterford, in particular renewable energy sites that are remote. Renewable energy projects generally require adequate road infrastructure to enable large heavy goods vehicles transport plant and materials. Access will also be required for operation and maintenance purposes and for decommissioning.

From an operations perspective, the biomass industry and associated technologies of AD and CHP are highly dependent on good road networks between points of supply and demand.

## 12.7 Ports / Harbours / Piers

Development of marine renewables and the associated servicing greatly depend on the capacity of port infrastructure. This Strategy recognises that the development of marine renewables at strategic locations may require necessary upgrades to local harbours, to cater for installation and maintenance of marine renewable technologies in order to provide the necessary infrastructure to maximise the potential of marine renewable energy.

## 12.8 Energy Storage

Renewable energy sources have great potential to reduce dependency on fossil fuels and greenhouse gas emissions. Despite this many of the resources have intermittent or variable output, therefore if they are not harnessed the energy goes to waste. In this regard, the installation of energy storage facilities is critical to store the excess electrical energy generated by renewable energy technologies and when demand is low. This stored electrical energy will provide a balance to the grid when demand is high and output from renewables is low. There are a number of storage systems which offer potential including pumped hydroelectric energy storage (PHES), battery storage and thermal storage.

## 12.9 Renewable Energy Support Schemes

Renewable energy projects are supported by government schemes and initiatives such as the Renewable Energy Feed in Tariff (REFIT), which is administered by the Department of Communications Energy and Natural Resources (DCENR). The REFIT schemes have been designed to incentivise the development of renewable electricity generation in order to ensure Ireland meets its goal of 40% of electricity coming from renewable sources by 2020. It is funded by the Public Service Obligation (PSO) which is paid for by all electricity consumers.

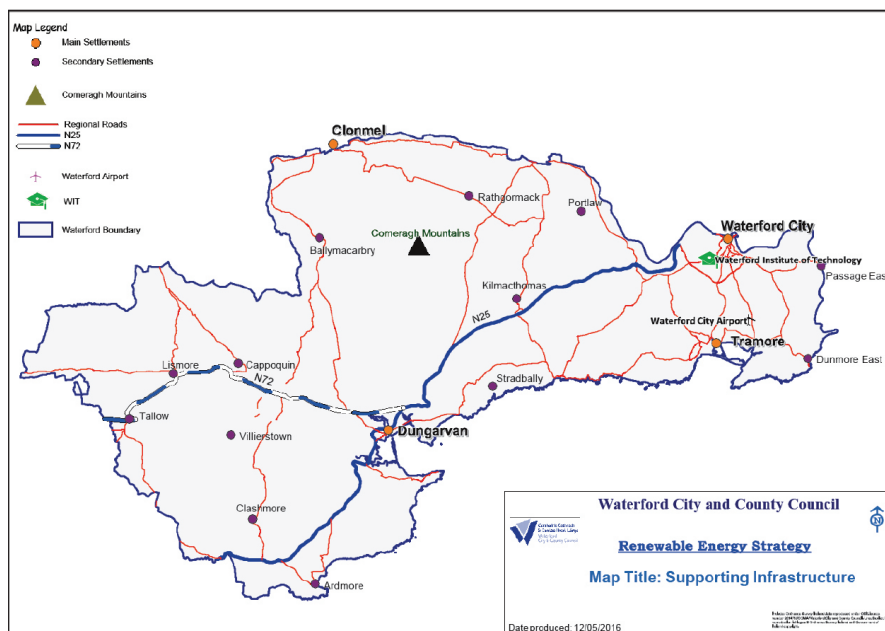

Figure 12.1 Supporting Infrastructure

## 13.0 STRATEGIC PLANNING CONSIDERATIONS

This Renewable Energy Strategy has been prepared as a strategic document which will underpin the policies and objectives of the current City and County Development Plans and inform the future review of these documents, in terms of policy and development management formulation.

Having considered the resource potential of various renewable technologies for Waterford, it is recognised that there are also considerations of an environmental and planning nature on the development of such renewable energy. These considerations include the natural environment; landscape; the built and cultural heritage; socio-economic impacts; the better integration of spatial planning and energy planning. Also, the issue of community consultation, community benefit and community involvement in renewable energy production are matters which also must be considered from a proper planning perspective.

It is the policy of Waterford City and County Council to promote and support the development of renewable energy technologies most suited to Waterford, to seek to reduce dependency on fossil fuels thereby enhancing the environmental, social and economic benefits to Waterford City and County.

### 13.1 Renewable Energy and Protection of the Environment

As per the Development Plans for Waterford City & County, the Council will assess all proposals for renewable energy development based on sustainable development principles.

The Council will seek to protect the conservation status of Natura 2000 sites and in this regard all renewable energy proposals which require planning permission will be screened for Appropriate Assessment in accordance with Articles 6(3) & 6(4) of the Habitats Directive, and where judged necessary a Natura Impact Statement shall be submitted.

The council shall have regard to Section 5 of the Planning & Development Regulations 2001 (as amended) in determining whether a renewable energy project should be subject to EIA<sup>22</sup>. This Strategy also highlights that EIA may be required for renewable energy proposals below statutory thresholds at the discretion of the Council. This principle also applies for renewable energy proposals not specifically listed in the development classes of EIA, e.g. Solar Farms. In this regard, the Council shall have regard to Schedule 7 of the Planning & Development Regulations 2001 (as amended) in deciding whether a renewable energy project is likely to have significant effects on the environment.

<sup>22</sup> Environmental Impact Assessment is “the process by which the anticipated effects on the environment of a proposed development are measured. If the likely effects are unacceptable, design measures or other relevant mitigation measures can be taken to reduce or avoid those effects” [www.epa.ie/monitoringassessment/assessment/eia/](http://www.epa.ie/monitoringassessment/assessment/eia/)

## **13.2 Renewable Energy and the Landscape**

The Scenic Landscape Evaluation map as set out in the Waterford County Development Plan classifies the landscape and features of Waterford and seeks to protect the landscape from inappropriate and unsustainable forms of development whilst also recognising that changes in the landscape brought about by development are inevitable.

Appropriate consideration of landscape capacity to accommodate renewable energy developments shall be carried out in the assessment of any proposal. This Renewable Energy Strategy also recognises the importance of undertaking a Landscape Character Assessment for Waterford in accordance with National landscape guidelines [Objective ENV 1 of Waterford County Development Plan 2011-2017].

## **13.3 Renewable Energy and consideration of External Factors**

The development of renewable energy can give rise to a variety of issues which have to be considered as part of the planning and development of renewable energy technologies.

### **13.3.1 Policy/legislative Considerations**

Regard should be had to certain plans and guidelines, e.g.

- Water Framework Directive and River Basin District Management Plans.
- Fisheries Ireland with particular reference to "Guidelines on the Planning, Designing, Construction and Operation of small scale Hydro-Electric Schemes and Fisheries". This document provides guidance on the development of hydro-electrical projects and associated impacts on fisheries;
- Rights of Way - land ownership rights. Renewable energy development can require agreements from neighbouring landowners in respect of supporting infrastructure, power lines etc.

### **13.3.2 Environmental Considerations**

- Drainage, surface water run-off and hydrology issues.
- Fish spawning and nursery areas as well as adult fish habitat - Construction and operational phases of renewable energy developments can have impacts on the fisheries resource and associated habitats if such developments are not undertaken in an environmentally sensitive manner;
- The management and control of invasive species;
- The maintenance of biodiversity not just in rivers, streams and lakes but also in the associated riparian zones and wetland areas;



- The impact of renewable energy on the conservation status of Natura 2000 sites.

### **13.3.3 Infrastructure Considerations**

- Availability of grid infrastructure – proximity to grid and capacity of grid. If site is too far from a suitable grid connection, then the cost and impact of cabling may make the project unviable.
- General access during construction/ongoing maintenance etc.

### **13.3.4 Socio-Economic Considerations**

- Balancing with other land uses, e.g. Agriculture, Aquaculture, Tourism and Leisure, Fishing sites, Navigation routes;
- Impact on sensitive receptors including local residents, areas of tourism and landscape amenity value, material assets including the architectural and archaeological heritage, and the cultural heritage.

## **13.4 Renewable Energy and Spatial Planning**

It is clear that the growth of Waterford will require a reliable, robust and energy efficient system to power homes, commercial/industrial landuses and transport needs over the lifetime of this RES and beyond. The City and County aspire to becoming as carbon neutral as possible and to maximise energy efficiency and renewable energy opportunities.

In achieving this aim, there is a need to strengthen links between renewable energy and spatial planning through County Development Plans, Strategic Development Zones and other local plans. This Strategy highlights the role of Spatial Energy Demand Analysis<sup>23</sup> as a means of bridging the gap between energy planning and landuse planning. Understanding existing and future energy demand in a spatial manner allows the necessary policy decisions regarding the integration of renewable energy technologies into the built environment and the landscape, to be made in a robust, informed and evidenced based manner.

This Strategy recognises that energy and climate change mitigation issues should be included as an additional layer in the development plan making process to ensure landuse planning and energy planning are fully integrated.

## **13.5 Renewable Energy and Community**

### **13.5.1 Renewable Energy and Community Consultation**

There is no statutory requirement for a developer to consult with the local community in respect of any renewable energy development proposal over and above the statutory requirements set out in the Planning & Development Act 2000 (as amended), i.e. a site notice, newspaper notice, public submission period and third party right of appeal to An Bord Pleanála.

However, the Planning Authority strongly encourages both developers and local communities to engage in meaningful consultation at the very early stages of the pre-planning process and ongoing throughout the planning process. Community engagement which continues through the construction and operation stages is highly recommended and will improve the likelihood of community acceptance of proposed renewable energy projects.

### **13.5.2 Renewable Energy and Community Ownership**

Some renewable energy technologies lend themselves particularly well to a cooperative model of ownership and operation. These include AD, biomass, wind farm, geothermal and district heating. In Ireland, the concept of community involvement is underutilised when compared with Scotland for example, where a dedicated body – ‘Community Energy Scotland’ provide guidance and advice to local communities on how they may become involved and benefit from community energy.

#### **Case Study Community Owned Renewable Energy Project Templederry Community Wind Farm**

Templederry Community Wind Farm in County Tipperary is a 100% community-owned and commissioned wind farm, the first of its kind successfully developed in Ireland. In 2001, the local community in Templederry came together to investigate ways to increase employment and investment in their area. The concept of renewable energy was examined and ‘Templederry Energy Resources’ was set up.

The Tipperary Energy Bureau and Leader were instrumental in providing assistance in the planning and development phase of the new wind farm, comprising 2 turbines. The group is now producing enough electricity to power 3,500 homes per annum.

### **13.5.3 Renewable Energy and Community Benefit**

The installation of a new energy infrastructure can give rise to a wide range of local concerns which can and do impact the smooth rollout of renewable energy projects and which can become a divisive issue in local communities. The primary concerns generally relate to noise, landscape and visual disturbance and the associated impact

on individuals, local communities and the environment.

The Government White Paper<sup>24</sup> has highlighted a number of actions which could widen the opportunity for greater community participation in renewable energy projects and in turn bring about greater social acceptance for renewable energy projects. These actions include:

- Development of a framework for how communities can share in the benefits of substantial new energy infrastructure which is located in their area;
- Examination of shared-ownership opportunities for renewable energy projects in local communities;
- Developing mechanisms to allow communities to avail of payment for electricity, such as the ability to participate in power purchase agreements;
- Support of the emerging energy co-operative movement as one means of facilitating community participation.

Waterford City & County Council would welcome the provision of national guidance and statutorily based regulation on the matter of community benefit<sup>25</sup>.

## **13.6 Renewable Energy Strategy & Monitoring**

The monitoring of this Renewable Energy Strategy primarily relates to the achievement of the national energy and energy efficiency targets set out under the NREAP and the NEEAP whilst also ensuring the protection of the environment.

An energy balance has been prepared as part of this Renewable Energy Strategy including projections for energy use up to 2030. A key indicator of the success in the promotion, planning and development of renewable energy in Waterford will be the assessment of this energy balance and whether the targets have been achieved over the lifetime of this Strategy.

The Renewable Energy Strategy will form part of the City and County Development Plans and will be reviewed in line with said plans.

---

<sup>24</sup> Ibid.

<sup>25</sup> *Guidelines on Community Gain: DCENR and DECLG are examining the issue of community benefit as part of a Renewable Electricity Policy and Development Framework. The issue of appropriate benefits to local communities will be addressed under the Framework.*

# APPENDIX 1

## Glossary of Terms

### **Anaerobic Digestion**

The process whereby bacteria break down organic material in the absence of oxygen yielding a biogas which can be combusted to generate electricity and heat.

### **Bio-fuels**

Fuels derived from biomass.

### **Biomass**

Biological material derived from organic materials, either directly from plants or indirectly from industrial, commercial, domestic or agricultural products, which can be converted to fuel for electricity, heating or transport.

### **Combined Heat & Power (CHP)**

Combined heat and power is the production of heat and electricity in a single process.

### **District Heating**

District Heating is a local heating network facilitated through underground pipes and a centralised heat source, usually operated in conjunction with CHP.

### **Greenhouse Gases (GHG)**

Greenhouse gases are gases that trap heat in the atmosphere. The most significant impact comes from carbon dioxide, nitrous oxide, methane and fluorinated gases.

### **Geothermal Energy**

Geothermal energy refers to heat energy stored in the ground. It can be classified as either 'deep' or 'shallow' depending on the depths involved.

### **Pumped Hydroelectric Energy Storage (PHES)**

A method of storing electrical energy as potential energy by pumping water from a reservoir or lake to another reservoir at a higher elevation and storing it for use in generating electricity when required.

### **REFIT**

REFIT stands for 'Renewable Energy Feed In Tariff' and is the primary means through which electricity from renewable sources is supported in Ireland.

**Smart Grid**

An evolution of the existing electricity grid incorporating operational and energy measures, maximising the efficiency of the electricity system.

**Waterford Energy Bureau (WEB)**

One of 15 regional/local energy agencies situated in Ireland, WEB provides a range of energy management, energy conservation and renewable energy services to the general public, to businesses and to Waterford City and County Council.

**Units of Power:**

<b>Watt (W):</b> Unit of power output	<b>Kilowatt (kW):</b> 1,000 Watts
<b>Megawatt (MW):</b> 1,000 kW of power	<b>GW (Gigawatt):</b> 1,000MW of power
<b>Terrawatt (TW):</b> 1,000 GW of power.	

**Units of Energy generated over time:**

<b>Kilowatt Hour (kWh):</b> 1 kW power output expended in one hour, the unit of electricity on a standard bill.	<b>Megawatt Hour (MWh):</b> 1 MW of power output expended in one hour.
<b>Gigawatt hour (GWh):</b> 1 GW of power output expended in one hour.	<b>Terrawatt hour (TWh):</b> 1 TW of power output expended in one hour.

**APPENDIX 2**

The Wind Energy Policy as per the Waterford County Development Plan 2011-2017 categorises the County into four areas of suitability for wind farm development:

Strategic Areas: Areas which are primarily suitable for wind energy and should be reserved for this purpose.

Preferred areas: Areas which are suitable and should generally be considered for permission unless local circumstances dictate otherwise.

Areas open to consideration: Proposals for wind farms will be assessed on their merits with responsibility on the developer to demonstrate suitability of the site.

No go Areas: Areas which are unsuitable for wind farm development.

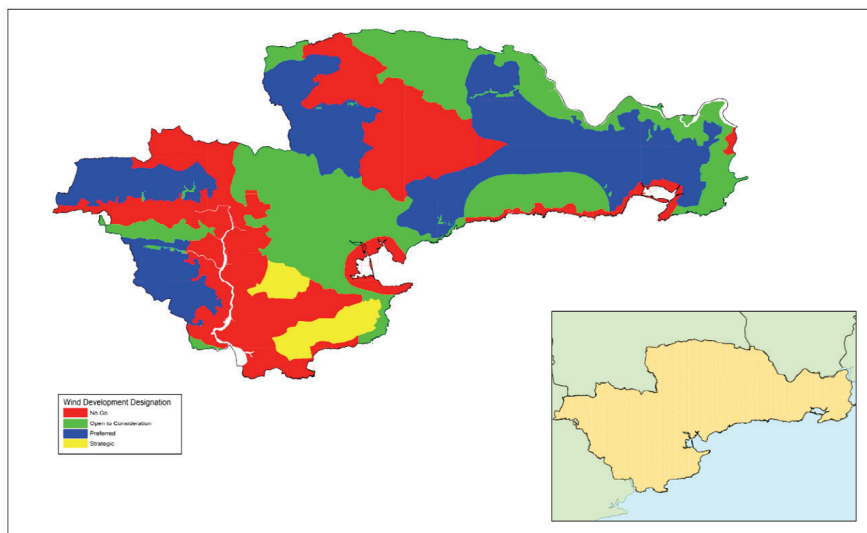

Wind Energy Designations (Waterford County Development Plan 2011-2017)

## APPENDIX 3

The following is a list of Grid Applications for Wind Farm and Solar Farm Developments in Waterford. These Grid applications are currently seeking an offer from the Commission of Energy Regulation to connect to the Grid. A grid offer does not infer a grant of planning permission.

Current Wind Farm Grid Applications			
Wind Farm	Turbines	Electricity Production (MW)	Annual Electricity Production (GWh/Yr)
Ballydurn 1	4	10	21.33
Ballydurn 2	2	4	8.53
Barracree	14	35	74.65
Carrigbrack East 1	8	20	42.66
Carrigbrack West 1	8	20	42.66
Coumnaappul	8	20	42.66
Coumnaappul East 1	8	20	42.66
Coumnaappul West 2	8	20	42.66
Knockanore 1	24	60	127.97
Moanbrack	3	8	17.06
Milk Hill 1	20	50	106.64
Fahafeelagh	2	4	8.53
Lisnageragh / Garranturton Brenan	28	70	149.30
Ballylangdon	9	23.1	49.27
Knocknalougha	4	10	21.33
Russelstown 1	10	24	51.19
<b>Total</b>	<b>150</b>	<b>398.1</b>	<b>849.09</b>

<b>Current Solar Farm Grid Applications</b>			
<b>Project Name</b>	<b>Irish Grid Co-Ordinates</b>	<b>MW</b>	<b>GWh/Yr</b>
Lackenfunne West Solar Farm	E223122, N92939	10.00	5.33
Knocknaglogh Upper Solar Farm	E218073, N90563	30.00	15.99
Ballygagin Upper Solar Farm	E222733, N92807	4.00	2.13
Carriglong Solar Park	E258834, N104727	16.00	8.53
Towergare PV	E258780, N106848	12.00	6.40
Cooltubbrid West Solar Farm	E239051, N104490	4.00	2.13
Donkey Aters SPV	E251162, N108519	3.99	2.13
Mountboltan	E246715, N117175	4.95	2.64
Killowen PV	E247380, N116660	3.99	2.13
Ballymoodranagh North Solar Farm	E206136, N98157	10.00	5.33
Ernesiders SPV	E262131, N104312	4.00	2.13
Clashganny South Solar Farm	E246194, N116082	10.00	5.33
Clashganny Solar Farm	E246791, N116643	4.00	2.13
Amberhill Solar Farm	E250617, N108593	4.00	2.13
Blackknock Solar	E251950, N107336	4.00	2.13
Ballymac Hybrid Storage and Solar PV Phase 1	E223702, N95240	3.99	2.13
Ballymac Hybrid Storage and Solar PV Phase 2	E223702, N95240	3.99	2.13
Ardsmen SPV	E261972, N105420	4.00	2.13
Monvoy Solar	E257665, N102737	4.00	2.13
Beallough Lake	E245020, N113680	0.50	0.27
Kilmacomma Solar Farm	E220199, N119313	18.00	9.59
Rincrew	E209250, N80570	4.95	2.64
Ballymoodranagh East Solar Farm	E206136, N98157	4.00	2.13
Clashnagoneen Solar Farm	E214918, N97829	4.00	2.13
Ballyhane Solar Farm	E214963, N97409	4.00	2.13
<b>Total</b>		<b>176.36</b>	<b>94.01</b>



## APPENDIX 4

## SEA SCREENING REPORT

### 1. INTRODUCTION

As set out in the National Renewable Energy Action Plan 2010 and the National Energy Efficiency Action Plan 2014, Ireland has legally binding targets for renewable energy and energy efficiency which must be met by 2020. The NREAP 2010 sets out how Ireland intends to achieve the target of 16% renewable energy share of national energy consumption by 2020 in the following sectors:

Sector	Target for 2020
Electricity	40%
Heating & Cooling	12%
Transport	10%
<b>Overall Target</b>	<b>16%</b>

The EU 2030 Framework for Climate and Energy was adopted by EU leaders in October 2014 and sets a 40% GHG reduction on 1990 GHG levels, and an EU-wide target of 27% for renewable energy and energy savings by 2030.

The Climate Action and Low Carbon Development Act 2015 provides for the making of five-yearly National Mitigation Plans to specify the policy measures required to reduce greenhouse gas emission and a National Adaptation Framework to specify measures required in different sectors and by local authorities to mitigate against the negative effects of climate change.

In the context of European and national policy a Renewable Energy Strategy has been developed to support the policies and objectives of the Waterford City Development Plan 2012-2018, Waterford County Development Plan 2011-2017 and Dungarvan Town Plan 2012-2018. The Renewable Energy Strategy aims to ensure that Waterford is at the forefront of renewable energy production whilst equally promoting energy efficiency and conservation in all sectors of the economy.

The vision of the strategy is to maximise Waterford's renewable energy potential and its transition to becoming a more energy secure, low carbon county in line with national energy targets whilst balancing the need to protect the environmental, social and heritage assets of the city and county.

The strategic aims of the Renewable Energy Strategy are;

- To ensure that between now and 2030, there is a steady, progressive and measurable increase in the amount of renewable energy used in the electricity, heat and transport sectors in Waterford, commensurate with the achievement of the national target.

- To identify opportunities for various renewable energy technologies and resources applicable to Waterford.
- To maximise the opportunities for renewable energy development whilst safeguarding the environment and other amenities, subject to Strategic Environmental Assessment and Habitats Directive Assessment requirements.

Section 13 of the Strategy sets out the local authority’s policy arising from consideration of the legislative policy context, the existing energy profile of Waterford and the range of renewable energy technologies;

It is the policy of Waterford City and County Council to promote and support the development of renewable energy technologies most suited to Waterford, to seek to reduce dependency on fossil fuels thereby enhancing the environmental, social and economic benefits to Waterford City and County.

## 2. SCREENING STATEMENT

The requirements for SEA in Ireland are set out in the national regulations, **S.I. No. 435 of 2004** (European Communities (Environmental Assessment of Certain Plans and Programmes) Regulations 2004 and **S.I. No. 436 of 2004** (Planning and Development (Strategic Environmental Assessment) Regulations 2004 as amended by **S.I. No. 200 of 2011** (European Communities (Environmental Assessment of Certain Plans and Programmes) (Amendment) Regulations 2011) and **S.I. No. 201 of 2011** (Planning and Development (Strategic Environmental Assessment) (Amendment) Regulations 2011) respectively.

The Regulations 2004-2011 require case by- case screening of individual plans and programmes based on the criteria in Schedule 2A to the Planning and Development Regulations 2001. These criteria must be taken into account in determining whether or not significant effects on the environment would be likely to arise.

### Stage One - Pre-Screening

The first step in determining whether the Waterford Renewable Energy Strategy would require an SEA involved a pre-screening check. It allows rapid screening-out of plans and policies that are clearly not going to have any environmental impact and screening-in of those that definitely do require SEA.

Following the pre-screening exercise (Figure 1) it is apparent that it is necessary to conduct further screening to determine if a Strategic Environmental Assessment of the Waterford Renewable Energy Strategy is required. The Waterford Renewable Energy Strategy will provide a framework for development of renewable energy therefore it was necessary to determine whether an SEA would be required by testing it against environmental significance screening criteria.

Figure 1. Pre-Screening Decision Tree

Is the Plan/Policy subject to preparation and/or adoption by a national, regional or local authority?

OR

Prepared by an authority for adoption through a legislative procedure by Parliament or Government?

▶ ✓ **YES**

▶ **NO**

**SEA Not Required**

Is the Plan/Policy required by legislative, regulatory or administrative provisions?

▶ ✓ **YES**

▶ **NO**

**SEA Not Required**

Is the sole purpose of the Plan/Policy to serve national defence or civil emergency or is it a financial/budget P/P or is it co-financed by the current SF/ERDF programme?

▶ ✓ **NO**

▶ **YES**

**SEA Not Required**

Is the P/P prepared for agriculture, forestry, fisheries, energy, industry, transport, waste management, water management, telecoms, tourism, town and country planning or land use?

▶ **NO**

Is the P/P likely to have a significant effect on a Natura 2000 site which leads to a requirement for Article 6 or 7 assessments?

▶ **YES**

**SEA Required Go to Stage 2**

▶ ✓ **YES**

Does the P/P provide a framework for development consent for projects listed in the EIA Directive?

▶ **NO**

▶ **NO**

SEA Not Required

▶ ✓ **YES**

Will it determine the use of small areas at a local scale only and/or is it a minor modification of a P/P?

▶ **YES**  
✓

Does it provide a framework for development consent for projects?

▶ **YES**  
✓

**SEA may be Required Go to Task 2**

▶ **NO**

SEA Required Go to Stage 2

▶ **NO**

SEA Not Required

## **Stage Two - Environmental Significance Screening**

The application of environmental significance criteria is important in determining whether an SEA is required for small Plans/Policies or modifications to Plans/Policies. Annex II (2) of Directive 2001/42/EC sets out the “statutory” criteria that should be addressed when undertaking this stage.

## **Criteria for Determining the Likely Significance of Environmental Effects**

### *Characteristics of the Plan/Programme*

- i. the degree to which the plan or programme sets a framework for projects and other activities, either with regard to the location, nature, size and operating conditions or by allocating resources;

It is the purpose of the Waterford Renewable Energy Strategy to maximise Waterford’s renewable energy potential and its transition to becoming a more energy secure, low carbon county in line with national energy targets whilst balancing the need to protect the environmental, social and heritage assets of the city and county. The County Development Plan contains a Wind Energy Strategy which was subject to SEA in 2008.

- ii. the degree to which the plan or programme influences other plans and programmes including those in a hierarchy;

The Renewable Energy Strategy has been prepared for Waterford City and County in the context of EU and national renewable energy targets. Waterford has varied renewable energy resources with objectives to support the development of renewable energy contained in the Waterford County Development Plan 2011-2017 & Waterford City Development Plan 2013-2018. The purpose of the Renewable Energy Strategy is to provide a strategic document which will underpin these Plans and inform their future review.

The Renewable Energy Strategy examines the renewable energy potential for the city and county and considers the strategic planning factors contributing towards the deployment of renewable energy. It highlights the importance of integrating renewable energy and landuse planning. Developing a spatial understanding of existing and future energy demand allows the necessary policy decisions regarding the integration of renewable energy technologies into the built environment and the landscape, to be made in a robust, informed and evidenced based manner. The Strategy recognises that there is a need to strengthen links between renewable energy and landuse planning through County Development Plans, Strategic Development Zones and other local plans. The Strategy will form part of the Waterford City Development Plan 2012-2018, Waterford County Development Plan 2011-2017 and Dungarvan Town Plan 2012-2018, and will be adopted by way of variation to these plans.

- iii. the relevance of the plan or programme for the integration of environmental considerations in particular with a view to promoting sustainable development;

The Renewable Energy Strategy considers the resource potential of various renewable technologies for Waterford and recognises the considerations of an environmental and planning nature on the development of such renewable energy. These considerations include the natural environment; landscape; the built and cultural heritage; socio-economic impacts; the better integration of spatial planning and energy planning. Also, the issue of community consultation, community benefit and community involvement in renewable energy production are recognised as issues that must be considered from a proper planning perspective.

As per the County Development Plan, the Council will assess all proposals for renewable energy development based on sustainable development principles. The Council will seek to protect the conservation status of Natura 2000 sites and in this regard all renewable energy proposals which require planning permission will be screened for Appropriate Assessment in accordance with Articles 6(3) & 6(4) of the Habitats Directive, and where judged necessary a Natura Impact Statement shall be submitted.

The council shall have regard to Section 5 of the Planning & Development Regulations 2001 (as amended) in determining whether a renewable energy project should be subject to EIA. The Strategy highlights that EIA may be required for renewable energy proposals below statutory thresholds at the discretion of the Council. This principle also applies for renewable energy proposals not specifically listed in the development classes of EIA, e.g. Solar Farms. In this regard, the Council shall have regard to Schedule 7 of the Planning & Development Regulations 2001 (as amended) in deciding whether a renewable energy project is likely to have significant effects on the environment.

iv. environmental problems relevant to the plan or programme;

The development of renewable energy can give rise to a variety of issues which have to be considered as part of the planning and development of renewable energy technologies. Section 13 - Strategic Planning Considerations clearly sets out the breadth of environmental criteria that are required to inform consideration of renewable energy development proposals.

The Strategy states regard should be had to certain plans and guidelines, e.g.

- Water Framework Directive and River Basin District Management Plans.
- Fisheries Ireland with particular reference to "Guidelines on the Planning, Designing, Construction and Operation of small scale Hydro-Electric Schemes and Fisheries". This document provides guidance on the development of hydro-electrical projects and associated impacts on fisheries;
- Rights of Way - land ownership rights. Renewable energy development can require agreements from neighbouring landowners in respect of supporting infrastructure, power lines etc.

The Strategy lists Environmental Considerations as follows;

- Drainage, surface water run-off and hydrology issues.
- Fish spawning and nursery areas as well as adult fish habitat – Construction and operational phases of renewable energy developments can have impacts on the fisheries resource and associated habitats if such developments are not undertaken in an environmentally sensitive manner;
- The management and control of invasive species;
- The maintenance of biodiversity not just in rivers, streams and lakes but also in the associated riparian zones and wetland areas;
- The impact of renewable energy on the conservation status of Natura 2000 sites.

#### Infrastructure Considerations

- Availability of grid infrastructure – proximity to grid and capacity of grid. If site is too far from a suitable grid connection, then the cost and impact of cabling may make the project unviable.
- General access during construction/ongoing maintenance etc.
- Licence to generate electricity.
- Power purchase agreements.

#### Socio-Economic Considerations

- Balancing with other land uses, e.g. Agriculture, Aquaculture, Tourism and Leisure, Fishing sites, Navigation routes;
- Impact on sensitive receptors including local residents, areas of tourism and landscape amenity value, material assets including the architectural and archaeological heritage, and the cultural heritage.

Proposals for renewable energy development will be subject to EIA and AA Screening as per policies and objectives in the Waterford City Development Plan 2012-2018, Waterford County Development Plan 2011-2017 and Dungarvan Town Plan 2012-2018.

- v. the relevance of the plan or programme for the implementation of Community legislation on the environment (e.g. plans and programmes linked to waste-management or water protection).

The Renewable Energy Strategy is not a spatial land use plan but rather provides a

framework to support objectives in the Waterford City Development Plan 2012-2018, Waterford County Development Plan 2011-2017 and Dungarvan Town Plan 2012-2018 and inform their future review. Where such plans provide a framework for development consent for projects these projects will be subject to EIA and AA Screening at project inception stage.

### ***Characteristics of the Effects and of the Area Likely to be Affected***

- ii. the probability, duration, frequency and reversibility of the effects

It is anticipated that the strategic aims and policy to be adopted as part of the Renewable Energy Strategy will ensure that the effects of the resulting changes to the existing operating environment will not be significant. The probability that these effects will be environmentally significant in negative terms is low.

- ii. the cumulative nature of the effects

Cumulative negative environmental effects are not expected. As per the County Development Plan, the Council will assess all proposals for renewable energy development based on sustainable development principles. The Council will seek to protect the conservation status of Natura 2000 sites and in this regard all renewable energy proposals which require planning permission will be screened for Appropriate Assessment in accordance with Articles 6(3) & 6(4) of the Habitats Directive, and where judged necessary a Natura Impact Statement shall be submitted. The Wind Energy Strategy was subject to SEA in 2008 and sensitivity classes amended on the basis of the SEA. Whilst Solar Power is a new land use and energy form in the county there are anticipated benefits for biodiversity with a move from intensive agricultural practice to semi-natural type grassland which can be managed for enhanced biodiversity value.

- iii. the transboundary nature of the effects

The Renewable Energy Strategy relates to Waterford City and County and thus will not incur transboundary effects. Renewable Energy developments will be screened for EIA and AA and transboundary effects where required.

- iv. the risks to human health or the environment (e.g. due to accidents)

The Renewable Energy Strategy recognises the potential for impact on sensitive receptors including local residents. There is no statutory requirement for a developer to consult with the local community in respect of any renewable energy development proposal over and above the statutory requirements set out in the Planning & Development Act 2000 (as amended), i.e. a site notice, newspaper notice, public submission period and third party right of appeal to An Bord Pleanála.

However, the Strategy states the Planning Authority strongly encourages both developers and local communities to engage in meaningful consultation at the very early stages of the pre-planning process and ongoing throughout the planning process. Community engagement which continues through the construction and operation stages is highly recommended and will improve the likelihood of community acceptance of proposed renewable energy projects.

- v. the magnitude and spatial extent of the effects (geographical area and size of the population likely to be affected)

The area subject of the Strategy is the entire area of Waterford City and County. The population of this area is approximately 115,000

- vi. the value and vulnerability of the area likely to be affected due to
  - special natural characteristics or cultural heritage;

Waterford City Development Plan 2013-2019 and Waterford County Development Plan 2011-2017 identify the following protected areas/elements of the natural/cultural heritage:

- Protected Structures
- Sites of Archaeological Significance
- Areas with natural heritage designations

The Renewable Energy Strategy recognises the potential for impact on sensitive receptors including areas of tourism and landscape amenity value, material assets including biodiversity not just in rivers, streams and lakes but also in the associated riparian zones and wetland areas, the conservation status of Natura 2000 sites, the architectural and archaeological heritage, and the cultural heritage.

The Council will assess all proposals for renewable energy development based on sustainable development principles and will seek to protect the conservation status of Natura 2000 sites and in this regard all renewable energy proposals which require planning permission will be screened for Appropriate Assessment in accordance with Articles 6(3) & 6(4) of the Habitats Directive, and where judged necessary a Natura Impact Statement shall be submitted.

The Strategy states regard should be had to the Water Framework Directive and River Basin District Management Plans and Fisheries Ireland "Guidelines on the Planning, Designing, Construction and Operation of small scale Hydro-Electric Schemes and Fisheries".



- exceeded environmental quality standards or limit values;

It is not expected that any environmental quality standards will be exceeded or that the value of vulnerable areas limited as a result of the Waterford Renewable Energy Strategy.

- intensive land-use;

The Renewable Energy Strategy is not a spatial land-use plan. Any projects arising within the framework of the Renewable Energy Strategy that require development consent under planning legislation will be required to comply with land use and environmental policy of the Waterford City and Waterford County Development Plans.

- vii. the effects on areas or landscapes which have a recognised national, community or international protection status.

The Strategy recognises the importance of undertaking a Landscape Character Assessment for Waterford in accordance with national landscape guidelines [Objective ENV 1 of Waterford County Development Plan 2011-2017]. Any projects arising from the Renewable Energy Strategy that require development consent under planning legislation will be required to comply with land use and environmental policy of the Waterford City and Waterford County Development Plans.

### **Stage Three - Conclusions + Recommendation**

Following the screening process, whereby the strategic aims, policy and strategic planning considerations (section 13) of the Renewable Energy Strategy have been assessed against the environmental significance criteria as contained in Annex II (2) of the SEA Directive, **it is concluded that a Strategic Environmental Assessment is not required for the Waterford Renewable Energy Strategy.**

## **APPENDIX 5 AA SCREENING REPORT**

### **1. INTRODUCTION TO THE HABITATS DIRECTIVE AND ARTICLE 6 ASSESSMENT**

The aim of the European Habitats Directive (Council Directive 92/43/EEC on the conservation of wild habitats and of wild fauna and flora) is to create a network of protected wildlife sites in Europe, maintained at a favourable conservation status<sup>26</sup>.

<sup>26</sup> *The conservation status of a species can be taken as "favourable" when population dynamics data on the species concerned indicate that it is maintaining itself on a long term basis as a viable component of its natural habitats, the natural range of the species is neither being reduced nor is likely to be reduced for the foreseeable future and there is and will continue to be a sufficiently large habitat to maintain its populations on a long-term basis. Article 1 (i) of the*

Each member state must designate their most important natural areas as Special Areas of Conservation. The Directive specifies the scientific criteria on the basis of which SAC sites must be selected and very strictly curtails the grounds that can be used as justification for damaging a site. The network of sites is referred to as NATURA 2000 and includes SACs (Special Areas of Conservation) for protected habitats and species and SPAs (Special Protection Areas) for protected birds.

The European Habitats Directive (Council of the European Communities 1992) was transposed into Irish legislation by the European Communities (Natural Habitats) Regulations 1997 and amended in 1998, 2005 and 2011. The Birds and Habitats Regulations 2011 and (Part XAB) of the Planning and Development Act 2000 (as amended), set out the obligations of planning authorities under the Birds and Habitats Directives.

Article 6 of the Habitats Directive provides a strict assessment procedure for any plan or project not directly connected with or necessary to the management of a designated European site but which has the potential to have implications for the site in view of the site's conservation objectives.

## **2. GUIDANCE ON THE IMPLEMENTATION OF ARTICLE 6**

The European Commission's guidance on the provisions of article 6(3) and 6(4) of the Habitats Directive sets out four stages for Appropriate Assessment.<sup>27</sup>

**Stage 1. Screening** – the process which identifies the likely impacts upon a Natura 2000 site of a project or plan, either alone or in combination with other projects or plans, and considers whether these impacts are likely to be significant;

**Stage 2. Appropriate assessment** – the consideration of the impact on the integrity of the Natura 2000 site of the project or plan, either alone or in combination with other projects or plans, with respect to the site's structure and function and its conservation objectives. Additionally, where there are adverse impacts, an assessment of the potential mitigation of those impacts;

**Stage 3. Assessment of alternative solutions** – the process which examines alternative ways of achieving the objectives of the project or plan that avoid adverse impacts on the integrity of the Natura 2000 site;

**Stage 4. Assessment where no alternative solutions exist and where adverse impacts remain** – an assessment of compensatory measures where, in the light of an assessment of imperative reasons of overriding public interest (IROPI), it is deemed that the project or plan should proceed.

---

*Habitats Directive 92/43/EEC*

*The conservation status of a habitat can be taken as "favourable" when its natural range and area it covers within that range is stable or increasing and the ecological factors that are necessary for its long-term maintenance exist and are likely to continue to exist for the foreseeable future.*

<sup>27</sup> *Assessment of plans and projects significantly affecting Natura 200 sites- methodological guidance on the provisions of Article 6(3) and 6 (4) of the Habitats Directive 92/43/EEC.*

*Managing Natura 2000 sites The provisions of Article 6 of the Habitats Directive 92/43/EEC.*  
European Commission (2002)

### **3. PROCEDURE FOR STAGE ONE SCREENING**

This report consists of a screening of the strategic aims and policy of the Waterford Renewable Energy Strategy 2016-2030.

This stage examines the likely effects of the strategic aims and policy on Natura 2000 sites in Waterford and within a 15km radius of the county and considers whether it can be objectively concluded that these sites will not be significantly impacted. This assessment comprises four steps:-

#### **Step 1: determining whether the project or plan is directly connected with or necessary to the management of the site: -**

The local authority's policy arising from consideration of the legislative policy context, the existing energy profile of Waterford and the range of renewable energy technologies is as follows;

It is the policy of Waterford City and County Council to promote and support the development of renewable energy technologies most suited to Waterford, to seek to reduce dependency on fossil fuels thereby enhancing the environmental, social and economic benefits to Waterford City and County.

The policy is not directly connected to the management of any Natura 2000 sites.

#### **Step 2: describing the project or plan and the description and characterisation of other projects or plans that in combination have the potential for having significant effects on the Natura 2000 site;**

The strategic aims of the Renewable Energy Strategy are;

- To ensure that between now and 2030, there is a steady, progressive and measurable increase in the amount of renewable energy used in the electricity, heat and transport sectors in Waterford, commensurate with the achievement of the national target.
- To identify opportunities for various renewable energy technologies and resources applicable to Waterford.
- To maximise the opportunities for renewable energy development whilst safeguarding the environment and other amenities, subject to Strategic Environmental Assessment and Habitats Directive Assessment requirements.

The Strategy does not identify site specific locations with regard to suitability for the range of renewable energy technologies. The County Waterford Wind Energy Strategy was subject to SEA in 2008 and sensitivity classes were amended to extend a No-Go area in the basis of potential significant impacts on the River Licky Freshwater Pearl Mussel Catchment.

### **Step 3: Identifying the potential effects on the Natura 2000 site;**

The DoEHLG Guidance on Appropriate Assessment on Plans and Projects in Ireland (December 2009) states that all N2000 sites within or adjacent the county must be mapped and tabulated, and site integrity and site conditions necessary to support the site integrity must be indicated.

The information presented in Table 1 comprises a breakdown of Natura 2000 sites within Waterford. The N2000 sites are listed by designation; Special Areas of Conservation / Special Protection Areas. The following information is listed for each N2000 site:

- Site code
- Site name
- Qualifying interests
- Conservation objectives
- Threats to site integrity

Table 2 details sites outside Waterford but within a 15km buffer zone of the county.

### **Step 4: Assessing the significance of any effects on the Natura 2000 site.**

The screening stage involves application of the precautionary principle proportional to the policy/objective and the Natura 2000 site in question. The proposed strategic aims and policy and their potential impact on the N2000 have been screened to ascertain if the Renewable Energy Strategy is likely to have significant effects on any Natura 2000 sites, using the following framework.

- N2000 site
- Qualifying interests
- Threats to site integrity
- Potential impacts from proposed policy
- Risk of significant impact (Y/N)
- Potential 'in combination' impacts
- Risk of significant impacts (Y/N)
- Avoidance and (then) mitigation measures
- Action required: objective/action change needed / rewording /

Where no significant effects are found, the Strategy is accepted and a Finding of no Significant Effects Report is concluded and no further assessment is required.

Where the proposed policy does have a significant effect, then the policy needs to be amended or rejected and a Stage 2 Appropriate Assessment is required.

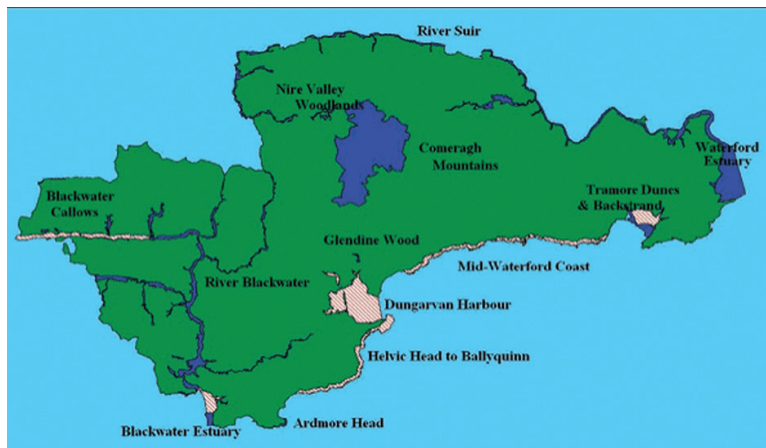

Table 1: Natura 2000 sites within Waterford

Waterford		Special Areas of Conservation (SACs)	
Site code Site name	Qualifying interests	Conservation objectives	Threats to site integrity
0002137 Lower River Suir	<p>Alluvial Wet Woodlands and Yew Wood,</p> <p>Floating River Vegetation, Atlantic Salt Meadows, Old Oak Wood and Eutrophic Tall Herbs</p> <p>Sea Lamprey, Brook Lamprey, River Lamprey, Freshwater Pearl Mussel, Crayfish, Twaité Shad, Atlantic Salmon, Otter</p>	To maintain or restore the favourable conservation condition of the Annex I habitat(s) and/or the Annex II species for which the SAC has been selected.	<p>Obstructions, impassable weirs, gross pollutants, specific pollutants, channel maintenance, man-made barriers to migration, eutrophication, leisure fishing drift netting, use of pesticides, fertilisation, removal of hedges and copses, removal of scrub, felling of native or mixed woodland, professional fishing(including lobster pots and fyke nets)hunting, trapping, poisoning, poaching, sand and gravel extraction, mechanical removal of peat, urbanised areas, human habitation, continuous urbanisation, industrial or commercial areas, discharges, disposal of household waste, industrial waste, inert materials, other discharges, routes, autoroutes, bridge, viaduct, water pollution, other forms of pollution, infilling of ditches, dykes, pods, pools, marshes or pits, drainage, management of aquatic and bank vegetation for drainage purposes, removal of sediments, canalisation or modifying structures of inland water course</p> <p>Overgrazing, infilling and reclamation, inappropriate grazing levels and invasive species, clearance for agriculture or felling for timber, planting of non-native conifers,</p> <p>Increased development</p>
0002123 Ardmore Head	Dry coastal heath and vegetated sea cliffs.	To maintain or restore the favourable conservation condition of the Annex I habitat(s) and/or the Annex II species for which the SAC has been selected.	Amenity use, residential and other development in adjacent areas, encroachment of scrub

<p>000072</p> <p>Blackwater River</p> <p>(Cork/ Waterford)</p>	<p>Estuary, Mudflats, Shingle Banks, Salt Meadows, Floating River Vegetation, Old Oak Woods, Alluvial Woodland, Yew Woodland, Freshwater Pearl Mussel, White-clawed Crayfish, Shad, Lampreys, Salmon, Otter, Killarney Fern</p>	<p>To maintain or restore the favourable conservation condition of the Annex I habitat(s) and/or the Annex II species for which the SAC has been selected.</p> <p>To restore the favourable conservation condition of the Freshwater Pearl Mussel in the Blackwater River SAC.</p>	<p>Professional fishing, taking of flora, fauna,</p> <p>Water pollution, climate change, change in species composition, aquaculture, bait digging, aggregate extraction, industrialisation, port/marina, communications networks, water pollution, reclamation of land, coastal protection works, invasion by a species, erosion and accretion, overgrazing, infilling and reclamation, inappropriate grazing levels, clearance for agriculture or felling for timber, increased development</p> <p>Obstructions, impassable weirs, channel maintenance, barriers, eutrophication, leisure fishing, drift netting</p> <p>use of pesticides, fertilisation, removal of hedges and copses, removal of scrub, felling of native or mixed woodland, professional fishing(including lobster pots and fyke nets)hunting, trapping, poisoning, poaching, sand and gravel extraction, mechanical removal of peat, urbanised areas, human habitation, continuous urbanisation, industrial or commercial areas, discharges, disposal of household waste, industrial waste, inert materials, other discharges, routes, autoroutes, bridge, viaduct, water pollution, other forms of pollution, infilling of ditches, dykes, pods, pools, marshes or pits,</p> <p>drainage, management of aquatic and bank vegetation for drainage purposes, removal of sediments, canalisation or modifying structures of inland water course</p> <p>Collection of samples, outdoor recreation, woodland clearance, overgrazing,</p> <p>hydrocarbons, global warming, climate change, modifications to the hydrology of sites through afforestation, road development or hydro-electric engineering. Air pollution</p>
--	---	--	---

<p>001952 Comeragh Mountains</p>	<p>Blanket bog, Dry, Wet and Alpine Heath, Rocky Slopes, Oligotrophic Lakes, Floating River Vegetation, Shining Sicklemoss</p>	<p>To maintain or restore the favourable conservation condition of the Annex I habitat(s) and/or the Annex II species for which the SAC has been selected.</p>	<p>Agriculture, burning, sand and gravel extraction, urbanisation, industrialisation, acidification, tropospheric ozone and nitrogen enrichment caused by atmospheric deposition</p> <p>Abandonment, overgrazing, burning, quarrying, outdoor recreation</p>
<p>002324 Glendine Wood</p>	<p>Semi-natural Woodland with rare assemblages of Ground Flora.</p>	<p>To maintain or restore the favourable conservation condition of the Annex I habitat(s) and/or the Annex II species for which the SAC has been selected.</p>	<p>Collection of samples, outdoor sport and leisure, human disturbance in localities used for recreational purposes. Woodland clearance, overgrazing, natural processes such as wind felling of trees. Modifications to the hydrology of a site through afforestation, road development or hydro-electric engineering, water pollution, air pollution, hydrocarbons, global warming, climate change</p>
<p>000665 Helvick Head</p>	<p>Vegetated Sea Cliffs and Dry Heath.</p>	<p>To maintain or restore the favourable conservation condition of the Annex I habitat(s) and/or the Annex II species for which the SAC has been selected.</p>	<p>Agriculture, burning, sand and gravel extraction, urbanisation, industrialisation, acidification, tropospheric ozone and nitrogen enrichment caused by atmospheric deposition</p>
<p>000668 Nier Valley Woods</p>	<p>Old Oak Woodlands and Dry Heath</p>	<p>To maintain or restore the favourable conservation condition of the Annex I habitat(s) and/or the Annex II species for which the SAC has been selected.</p>	<p>Inappropriate grazing levels and invasive species, clearance for agriculture or felling for timber, planting of non-native conifers</p> <p>Agriculture, burning, sand and gravel extraction, urbanisation, industrialisation, acidification, tropospheric ozone and nitrogen enrichment caused by atmospheric deposition</p>



002162 River Nore and River  Barrow  (Waterford Estuary)	Estuary, Mudflats, Salt Meadows, Floating River  Vegetation, Dry Heath, Marginal River Vegetation,  Petrifying Springs, Old Oak Woods, Alluvial Woods, White- clawed Crayfish, Freshwater Pearl Mussel, Whorl snail, Shad, Lampreys, Salmon, Otter, Killarney Fern	To maintain or restore the favourable conservation condition of the Annex I habitat(s) and/ or the Annex II species for which the SAC has been selected.	See above under County Carlow
00671  Tramore Dunes and  Back Strand	Mudflats and sandflats, shingle banks, salt meadows, embryonic, white and fixed dunes.	To maintain or restore the favourable conservation condition of the Annex I habitat(s) and/ or the Annex II species for which the SAC has been selected.	Erosion, walking, horseriding and non motorised vehicles, trampling, overuse, sea defence or coastal protection works, undergrazing, invasion by a species, camping and caravans, agricultural improvement, stock feeding, overgrazing, paths, tracks, cycle routes, golf courses, restructured agricultural land holding, disposal of household waste, sand and gravel extraction, other pollution or human activities, aquaculture, professional fishing, bait digging, removal of fauna, aggregate extraction, removal of beach material, industrialisation, port/marina, communication networks, water pollution, reclamation of land,
		<b>Special Protection Areas (SPAs)</b>	
<b>Site code Site name</b>	<b>Qualifying interests</b>	<b>Conservation objectives</b>	<b>Threats to site integrity</b>
Tramore Backstrand	Brent Geese, Golden Plover, Grey Plover, Black-tailed Godwit, Bar- tailed Godwit, Lapwing, Dunlin, Sanderling,	To maintain or restore the favourable conservation condition of the bird species listed as Special Conservation Interests for this SPA.	Disturbance, Water Quality, Invasive Species

Dungarvan Bay	<p>Brent Goose, Black-tailed Godwit , Bar-tailed Godwit, of international importance</p> <p>Nationally important numbers of Shelduck, Wigeon, Red-breasted Merganser, Grey Plover, Golden Plover, Lapwing, Knot, Sanderling, Dunlin, Redshank and Turnstone</p>	To maintain or restore the favourable conservation condition of the bird species listed as Special Conservation Interests for this SPA.	Disturbance, Water pollution, climate change, change in species composition, aquaculture, bait digging, aggregate extraction, industrialisation, port/ marina, communications networks, water pollution
Blackwater Callows	Whooper swan, Bewick's Swan, Golden Plover, Kingfisher	To maintain or restore the favourable conservation condition of the bird species listed as Special Conservation Interests for this SPA.	Disturbance, change in agricultural practices
Blackwater Estuary	Little Egret, Golden Plover, Bar-tailed Godwit, Sandwich Tern, Roseate Tern, Common Tern	To maintain or restore the favourable conservation condition of the bird species listed as Special Conservation Interests for this SPA.	Disturbance, Water pollution
Helvick Head Coast	<p>Peregrine, Chough</p> <p>Kittiwake and Guillemot</p>	To maintain or restore the favourable conservation condition of the bird species listed as Special Conservation Interests for this SPA.	Development, Change in agricultural practices, agricultural abandonment, encroachment of scrub, loss of close-sward grazing,

Mid-Waterford Coast	Peregrine, Chough	To maintain or restore the favourable conservation condition of the bird species listed as Special Conservation Interests for this SPA.	Development, Change in agricultural practices, agricultural abandonment, encroachment of scrub, loss of close-sward grazing,
---------------------	-------------------	---	--

Table 2: Natura 2000 sites within 15km of Waterford

County Cork		Special Areas of Conservation (SACs)	
Site code Site name	Qualifying interests	Conservation objectives	Threats to site integrity
Ballymacoda Bay SPA	Estuaries, salt meadows, mudflats and sandflats	To maintain or restore the favourable conservation condition of the Annex I habitat(s) and/or the Annex II species for which the SAC has been selected.	Professional fishing, taking for fauna, taking for flora, water pollution, climate change, change in species composition, Invasive Species, Erosion and accretion, Aquaculture, professional fishing, bait digging, removal of fauna, aggregate extraction;(removal of beach material, industrialization, Port/ Marina, communications networks, water pollution, reclamation of land, coastal protection works, invasion by a species
000072 Blackwater River (Cork/ Waterford)	Estuary, Mudflats, Shingle Banks, Salt Meadows, Floating River Vegetation, Old Oak Woods, Alluvial Woodland, Yew Woodland, Freshwater Pearl Mussel, White-clawed Crayfish, Shad, Lampreys, Salmon, Otter, Killarney Fern	To maintain or restore the favourable conservation condition of the Annex I habitat(s) and/or the Annex II species for which the SAC has been selected.	See County Waterford above

## 5. SCREENING ASSESSMENT

Table 4 presents issues concerning the conservation status of the larger Natura 2000 sites and species where they occur in Waterford

Table 4. Habitats Directive Assessment Matrix to determine nature of risk of significant effects on SACs and SPAs.

Natura 2000 Site SAC	Pressure Topic	Possible impacts from Proposed Policy	Risk of Significant Impact	Mitigation measure
Lower River Suir	Water quality Waste Water Treatment  (EPA classify Lower Suir Estuary trophic status as Intermediate, Upper Suir Estuary as Eutrophic) <sup>1</sup>	No significant impacts anticipated	No significant impacts anticipated	No significant impacts anticipated
Blackwater River	Water Quality and Waste Water Treatment  (EPA classify trophic status as eutrophic in both Upper and Lower Blackwater Estuary)	No significant impacts anticipated	No significant impacts anticipated	No significant impacts anticipated
River Nore and River Barrow including Waterford Estuary	Water quality  (EPA list trophic status as Intermediate) Waste Water Treatment	No significant impacts anticipated	No significant impacts anticipated	No significant impacts anticipated
Tramore Dunes and Back Strand	Recreational Pressure	No significant impacts anticipated	No significant impacts anticipated	No significant impacts anticipated
Comeragh Mountains	Recreational Pressure	No significant impacts anticipated	No significant impacts anticipated	No significant impacts anticipated

<b>Natura 2000 Site SPA</b>	<b>Pressure Topic</b>	<b>Possible impacts from Proposed policy</b>	<b>Risk of Significant Impact</b>	<b>Mitigation measure</b>
Helvick Head Coast	Disturbance	No significant impacts anticipated	No significant impacts anticipated	No significant impacts anticipated
Mid-Waterford Coast	Disturbance	No significant impacts anticipated	No significant impacts anticipated	No significant impacts anticipated
Dungarvan Bay	Water quality Waste Water Treatment  (EPA classify trophic status as Intermediate. SERBDMP state the area requires restoration to reach good status under the WFD by 2015).	No significant impacts anticipated	No significant impacts anticipated	No significant impacts anticipated
Tramore Back Strand	Disturbance	No significant impacts anticipated	No significant impacts anticipated	No significant impacts anticipated
<b>Annex II species</b>	<b>National Conservation Status<sup>2</sup></b>	<b>Threats to Conservation Status on a national level</b>		<b>Comment/Mitigation measure</b>
Freshwater Pearl Mussel	Bad	Water quality		No significant impacts anticipated
Killarney Fern	Good	Modifications to the hydrology of Killarney Fern sites through afforestation, road development		No significant impacts anticipated
Salmon	Bad	Water quality		No significant impacts anticipated
Crayfish	Poor	Water quality		No significant impacts anticipated
Twaite Shad	Bad	Water quality		No significant impacts anticipated
Otter	Poor	Water quality Clearance of riparian vegetation		No significant impacts anticipated
River Lamprey	Good	Water quality		No significant impacts anticipated
Sea Lamprey	Poor	Weirs and Channel maintenance		No significant impacts anticipated

## **5.2 POTENTIAL IMPACTS AND MITIGATION**

The Renewable Energy Strategy has had regard to national guidelines and policy documents. Section 13 - Strategic Planning Considerations of the Strategy clearly sets out the breadth of environmental criteria that are required to inform consideration of renewable energy development proposals.

The Strategy states regard should be had to certain plans and guidelines, e.g.

- Water Framework Directive and River Basin District Management Plans.
- Fisheries Ireland with particular reference to “Guidelines on the Planning, Designing, Construction and Operation of small scale Hydro-Electric Schemes and Fisheries”.

The Strategy lists Environmental Considerations as follows;

- Drainage, surface water run-off and hydrology issues.
- Fish spawning and nursery areas as well as adult fish habitat – Construction and operational phases of renewable energy developments can have impacts on the fisheries resource and associated habitats if such developments are not undertaken in an environmentally sensitive manner;
- The management and control of invasive species;
- The maintenance of biodiversity not just in rivers, streams and lakes but also in the associated riparian zones and wetland areas;
- The impact of renewable energy on the conservation status of Natura 2000 sites.

## **6. IMPACTS ON NATURA SITES WITHIN 15KM OF COUNTY WATERFORD**

There is 1 Natura 2000 site located within 15km of County Waterford- Ballymacoda Bay in Co. Cork and it will not be directly affected by the policy in the Renewable Energy Strategy.

All the River SACs within Waterford (Blackwater, Lower River Suir, Barrow and Nore,) traverse the county boundary with Counties Cork, South Tipperary and Kilkenny. All renewable energy proposals which require planning permission will be screened for Appropriate Assessment in accordance with Articles 6(3) & 6(4) of the Habitats Directive

- (a) Fig 4.1 Wind Energy Developments in Waterford
- (b) Fig 6.2 Water Courses in Waterford
- (c) Fig 7.1 Public and private forestry of Waterford
- (d) Fig 8.1 Marine Renewable Energy indicative development zone
- (e) Fig 8.3 Sea beds depth off the coast of Waterford

- (f) Fig 12.1 Energy infrastructure in Waterford
- (g) Fig 12.2 Support infrastructure
- (h) Wind Energy Designations (Waterford County Development Plan 2011-2017)

## **7. CONCLUSION**

A Habitats Directive Screening Assessment was carried out on the Waterford Renewable Energy Strategy involving review of conservation objectives and threats to site integrity for the range of Natura 2000 sites in Waterford

The strategic aims of the Renewable Energy Strategy include;

To maximise the opportunities for renewable energy development whilst safeguarding the environment and other amenities, subject to Strategic Environmental Assessment and Habitats Directive Assessment requirements and the Strategic Planning Considerations of Section 13 states the Council will seek to protect the conservation status of Natura 2000 sites and in this regard all renewable energy proposals which require planning permission will be screened for Appropriate Assessment in accordance with Articles 6(3) & 6(4) of the Habitats Directive and Section 177(v) of the Planning and Development Act 2000 as amended.

Thus, it is not considered the Renewable Energy Strategy will give rise to significant effects on Natura 2000 sites in Waterford City and County. This assessment should be read in conjunction with the Draft Renewable Energy Strategy and the accompanying SEA Screening Statement prepared in fulfilment of the SEA process.

(Footnotes)

- 1 *Ireland's Environment 2008 (EPA)*
- 2 *The Status of EU Protected Habitats and Species in Ireland DoEHLG 2008*

# APPENDIX 5 MAPS

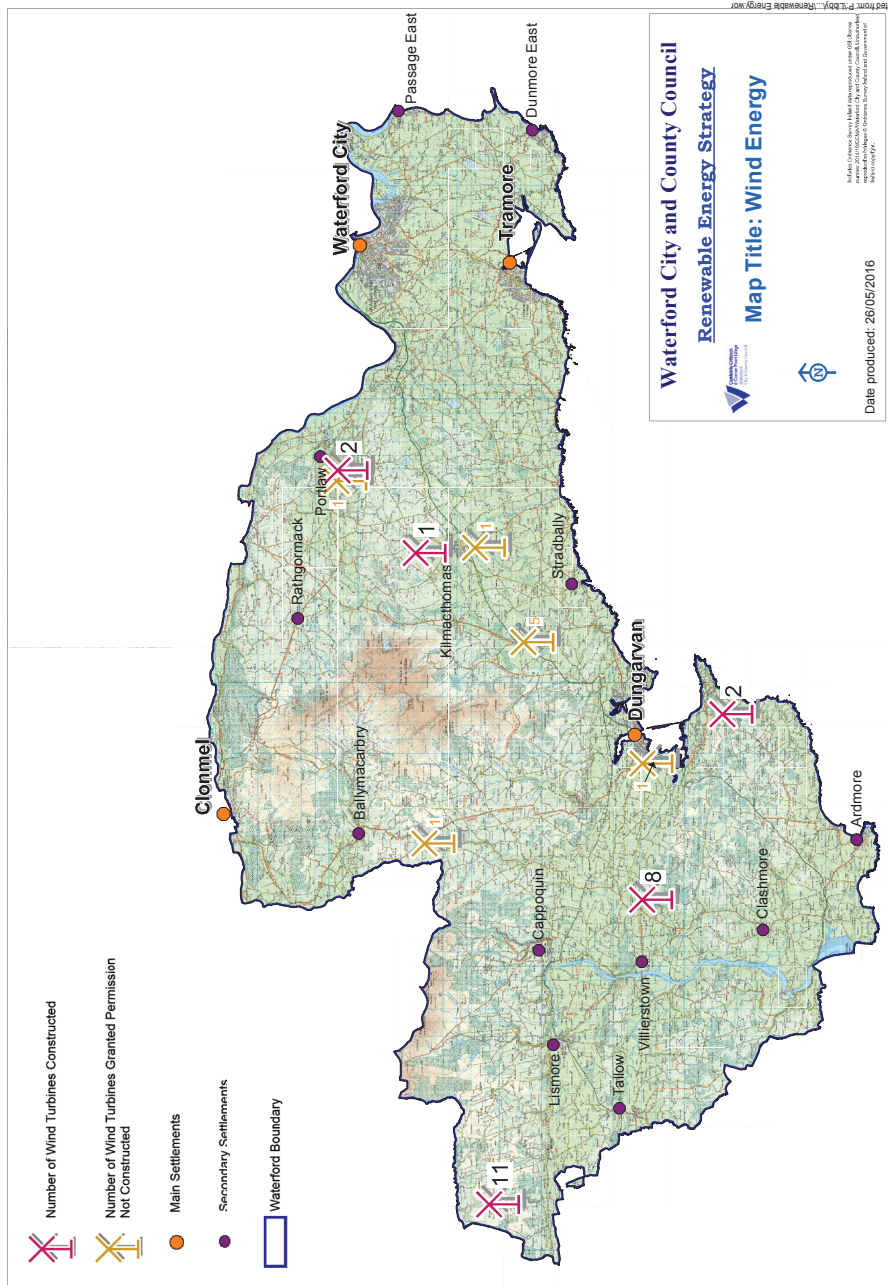

Fig 4.1 Wind Energy Developments in Waterford





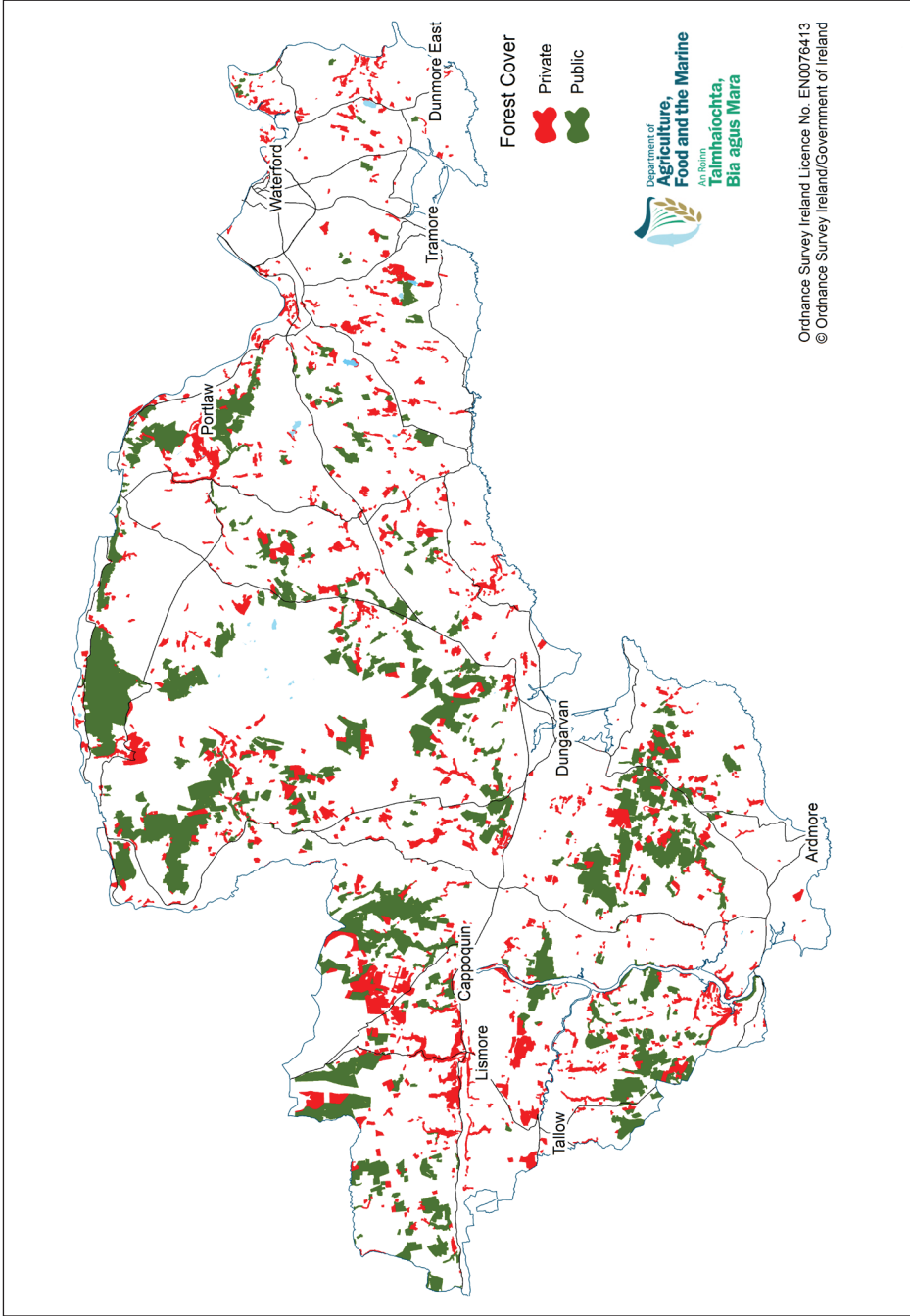

Fig 7.1 Public and private forestry of Waterford

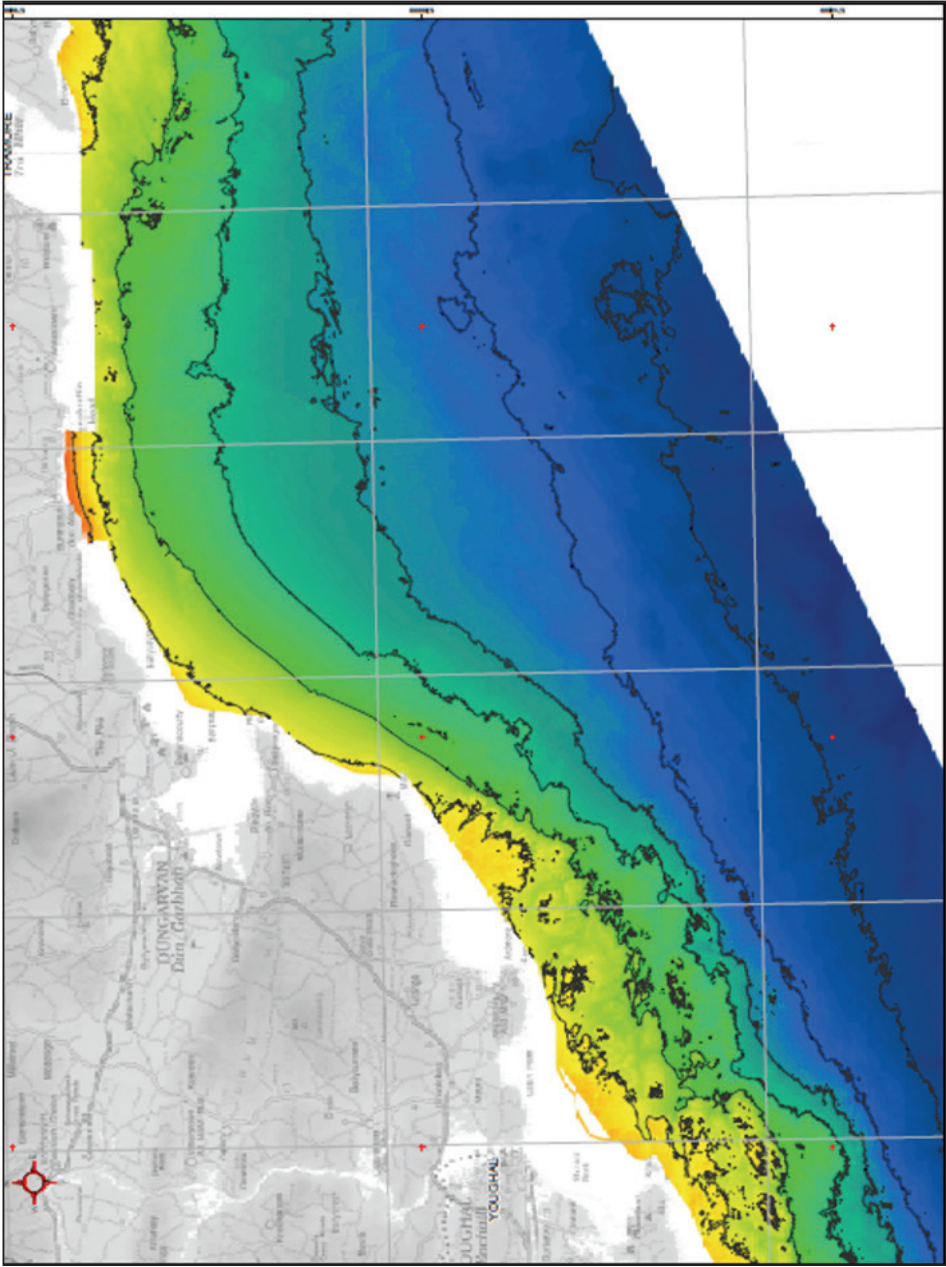

Fig 8.3 Sea beds depth off the coast of Waterford

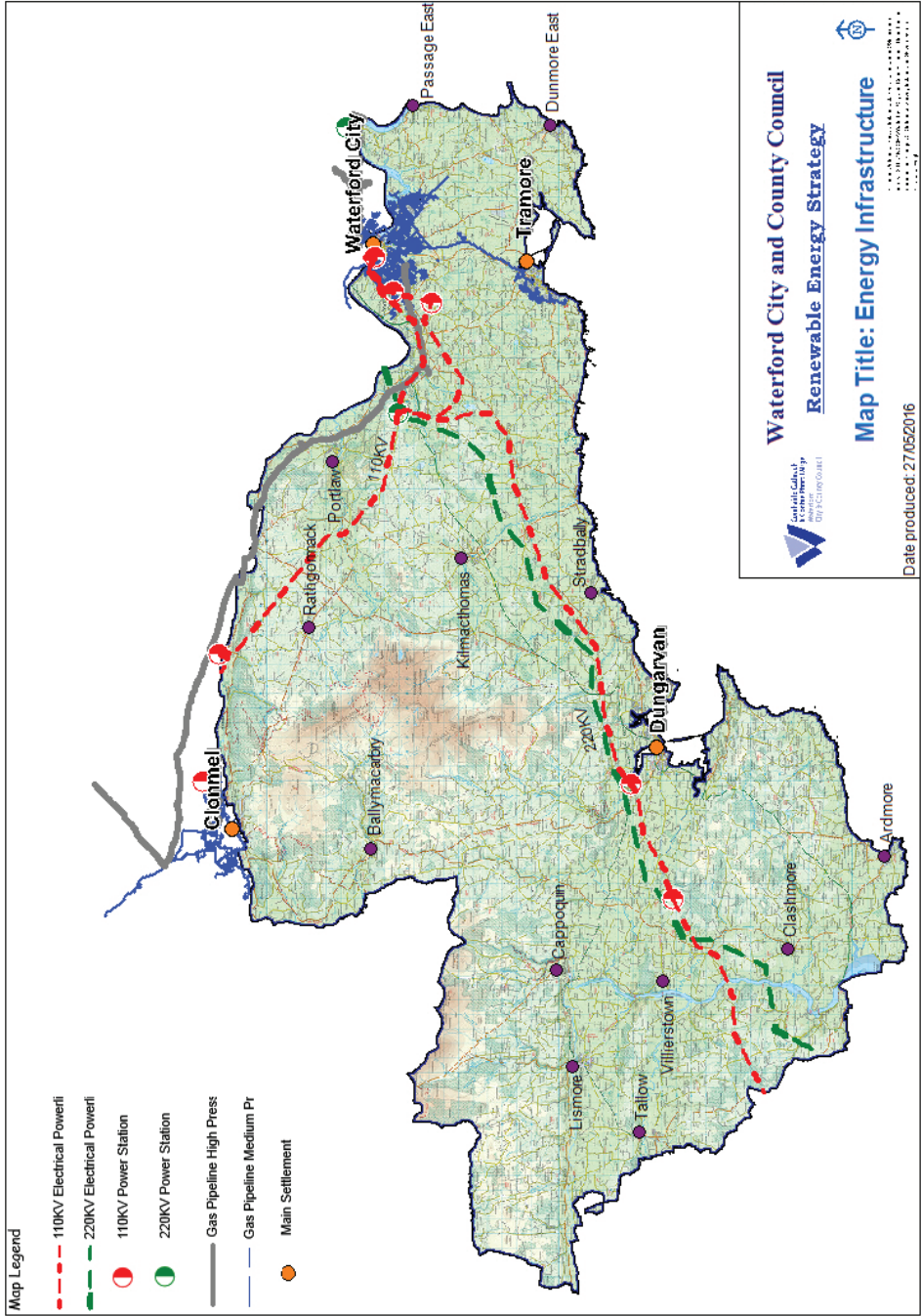

Fig.12.1 Energy infrastructure in Waterford



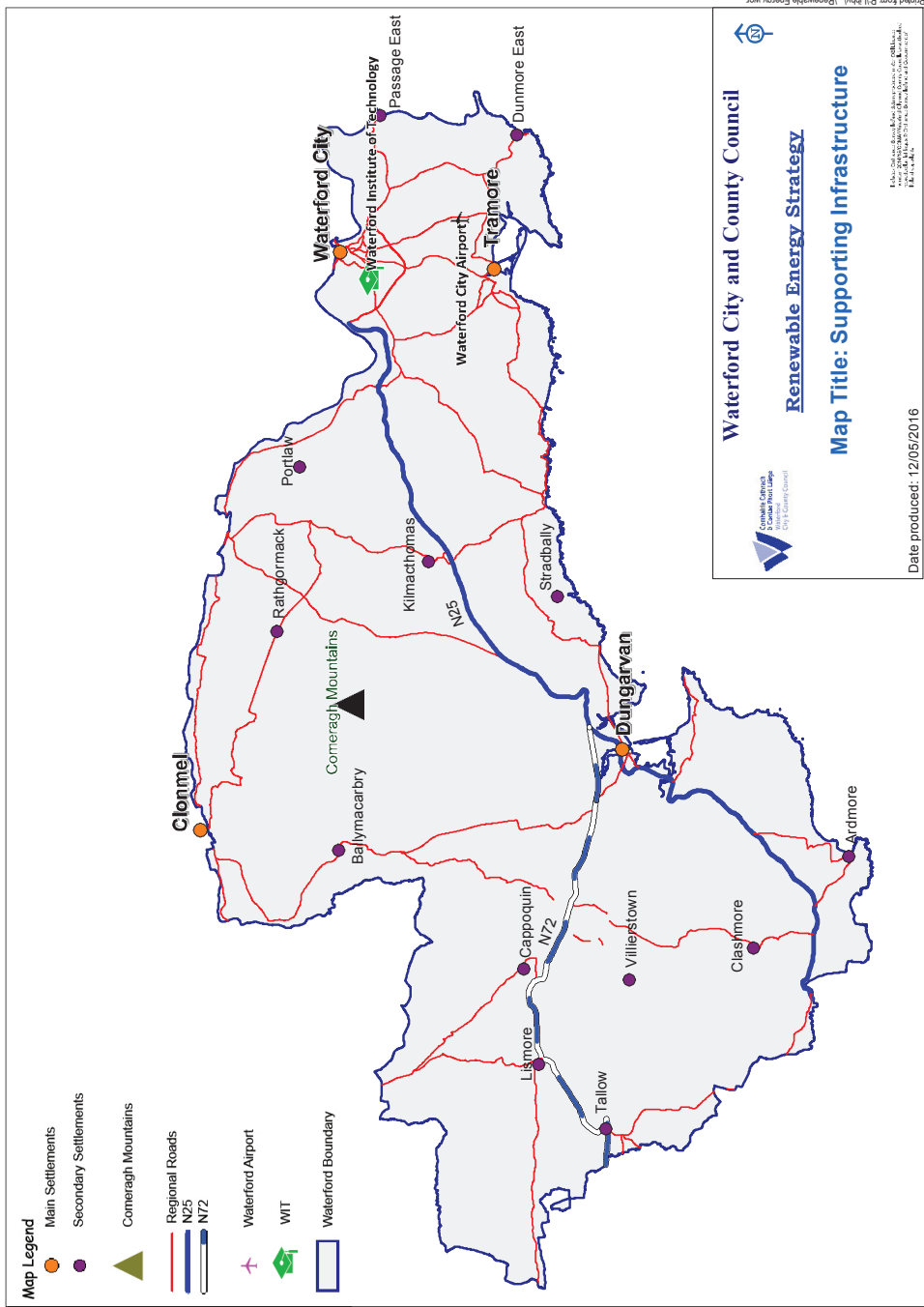
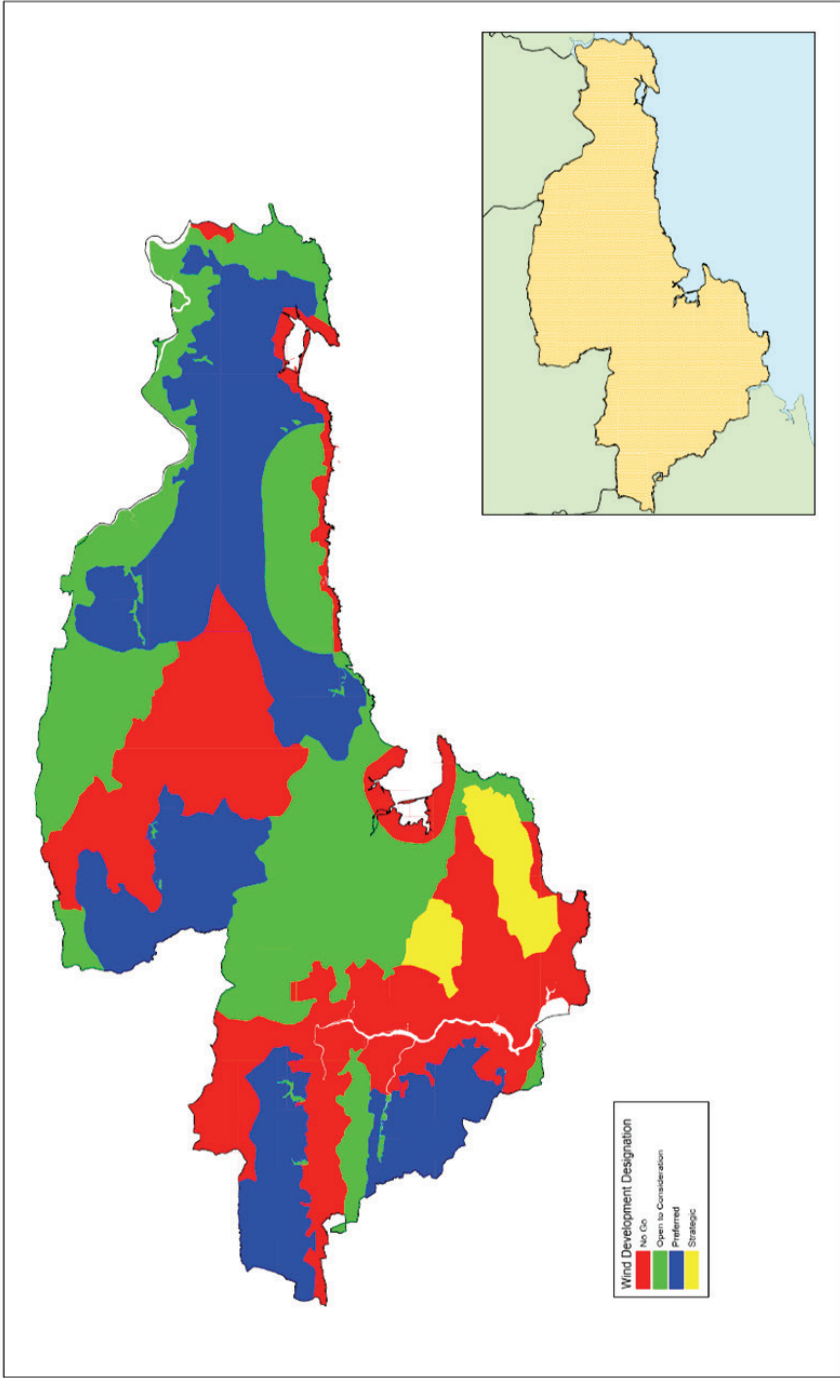

Fig 12.2 Support infrastructure



Wind Energy Designations (Waterford County Development Plan 2011-2017)



